

4817500COM Accent Cabinet

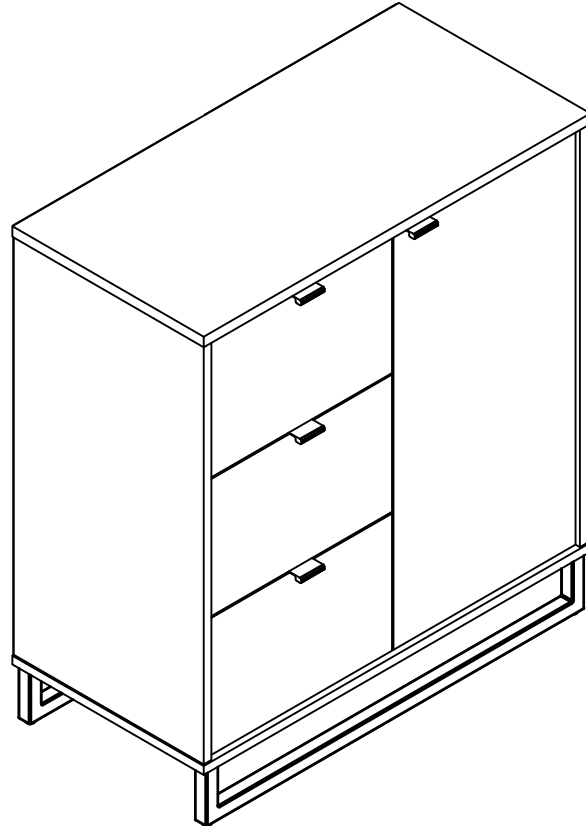

Date of Purchase ___ / ___ / ___
Lot Number:

B344817500COM0



Do Not Return This Product!
Contact our customer service team for help first.
Call: 1-800-489-3351 (toll free)
Monday-Friday 9am - 5pm CST
Visit: www.ameriwoodhome.com

THIS INSTRUCTION BOOKLET CONTAINS **IMPORTANT** SAFETY INFORMATION. PLEASE READ AND KEEP FOR FUTURE REFERENCE.

Secure Your Furniture

Keep your home and family safe with the wall anchor kit that is included with the product.

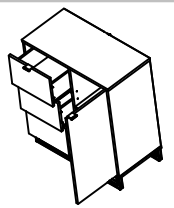

Serious or fatal crushing injuries can occur from tipping furniture.

WARNING: Manufacturer assumes no liability for improper installation or excessive loads placed on screws or bracket. This wall anchor is not a substitute for proper adult supervision.



Follow Ameriwood Home



Contact Us!

Do NOT return this product!

Contact our friendly customer service team first for help.

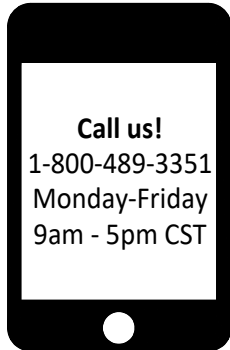

Visit ameriwoodhome.com to view the limited warranty valid in the U.S. and Canada.

Assembly Tips



Helpful Hints

PEOPLE NEEDED FOR ASSEMBLY: 1-2

- Open your item in the area you plan to keep it to avoid excessive heavy lifting.
- Identify, sort and count the parts before attempting assembly.
- Compression dowels are lightly tapped in with a hammer.
- Slides are labeled with a **R** (right) and **L** (left) for proper placement.
- Make sure to always face the point on the top of the Cam Lock towards the outer edge.
- Use all the nails provided for the back panel and spread them out equally.
- Back panel must be used to make sure your unit is sturdy.
- Do NOT use harsh chemicals or abrasive cleaners on this item.
- Never push, pull, or drag your furniture.



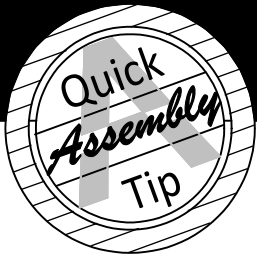

Before You Start

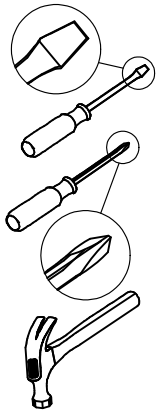

- ✓ Read through each step carefully and follow the proper order
- ✓ Separate and count all your parts and hardware
Parts are labeled on the surface or edge of the part
- ✓ Give yourself enough room for the assembly process
- ✓ Have the following tools: Flat Head Screwdriver, #2 Phillips Head Screwdriver and Hammer
- ✓ Caution: If using a power drill or power screwdriver for screwing, please be aware to slow down and stop when screw is tight. Failure to do so may result in stripping the screw.

Cam Lock Fastening System

This Cam Lock Fastening System will be used throughout the assembly process.

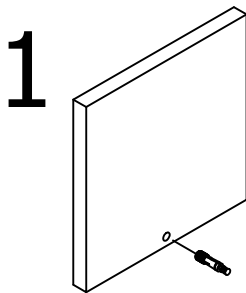

1 Press CAM BOLT into hole.

2

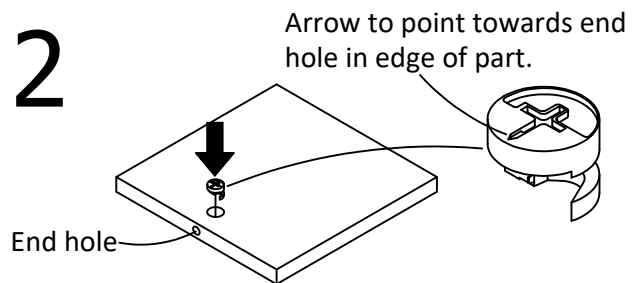

2 Press CAM LOCK into hole.

3

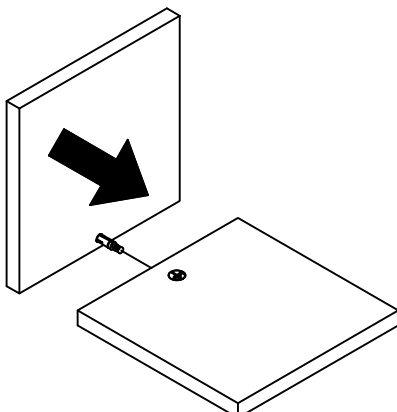

3 Press parts together so CAM BOLT inserts into edge hole.

4

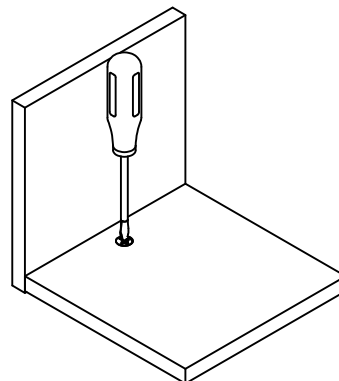

4 Using a screwdriver, turn the CAM LOCK clockwise to lock the CAM LOCK and CAM BOLT into their holes and fastening parts together.

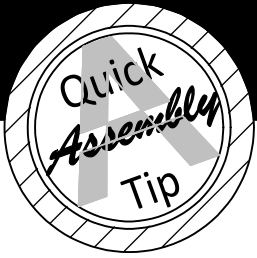

Before You Start

Please Note:

You may need to lightly tap the wood dowels into the holes during your assembly process.

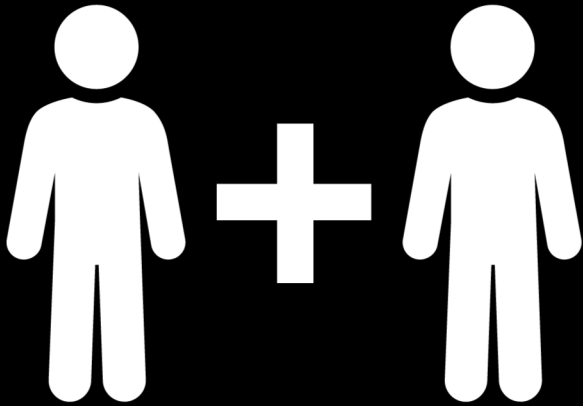
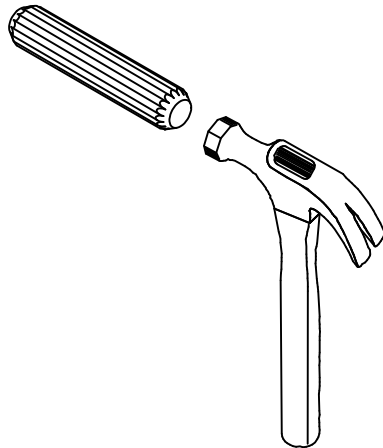

2 PEOPLE NEEDED FOR ASSEMBLY

**2 PERSONAS NECESITADAS
PARA LA ASAMBLEA**

**2 PERSONNES NÉCESSAIRES
POUR L'ASSEMBLAGE**

CAUTION: Failure to use 2 people for assembly could result in unit damage or personal injury.

PRECAUCIÓN: Si no se utilizan 2 personas para el ensamblaje, se pueden producir daños en la unidad o lesiones personales.

ATTENTION: Échec d'utiliser 2 personnes pour l'assemblage peut causer du dommage au meuble ou causer des blessures.

Board Identification

Not actual size

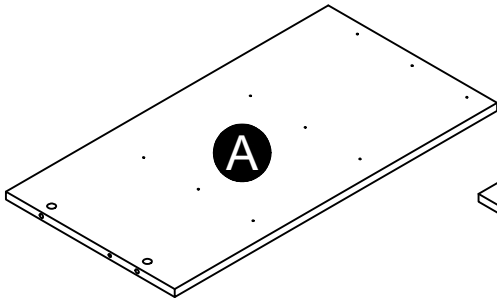

Left Panel
34817408010

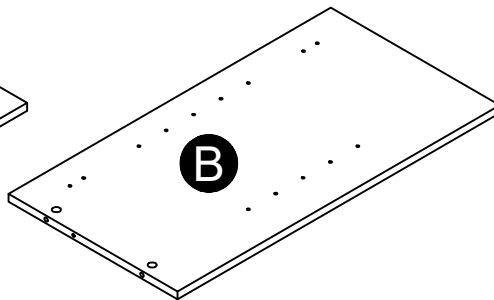

Right Panel
32189408020

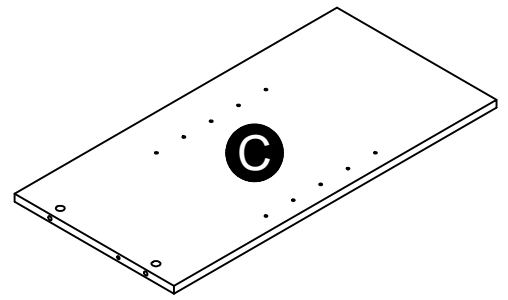

Partition
34817408030

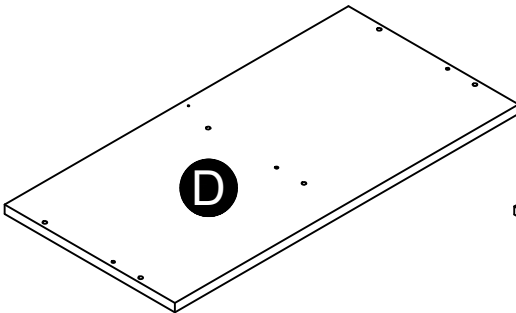

Top
34817408040

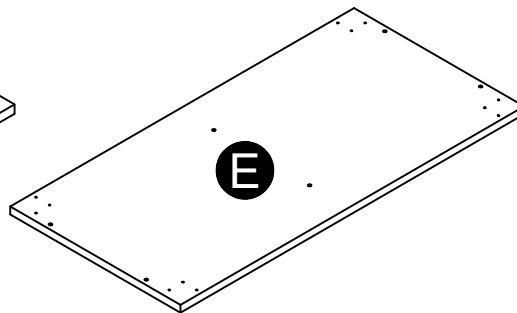

Bottom
34817408050

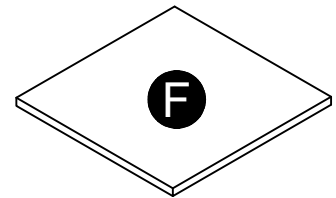

Adjustable Shelf
34817408060

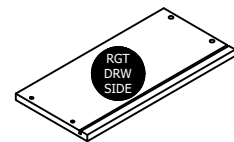

Right Drawer Side (x3)
3999116734641R

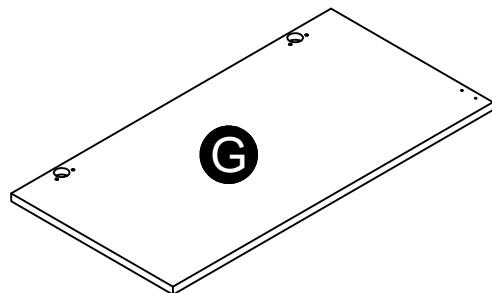

Door
32189355070

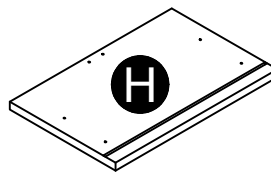

Drawer Front (x3)
34817355080



Drawer Back (x3)
39991167033218B

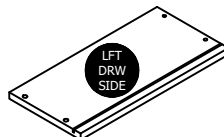

Left Drawer Side (x3)
3999116734641L

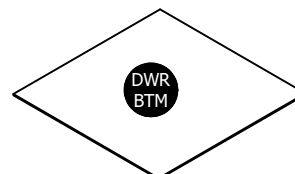

Drawer Bottom (x3)
39991340034310D

Board Identification

Not actual size

This piece is paperboard construction. It is not made from wood, but is required for the assembly of your unit.

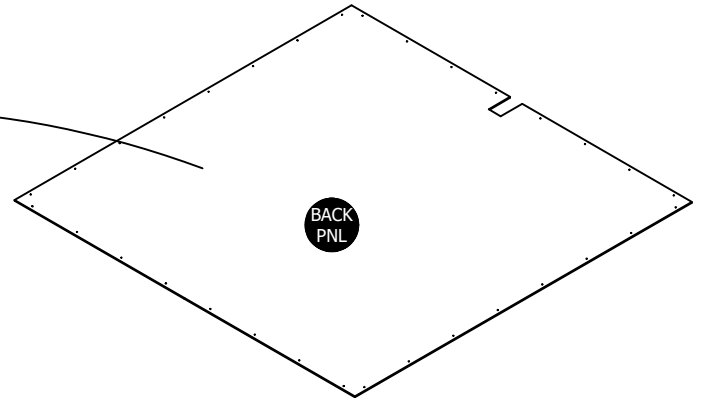

Back Panel
K481740800

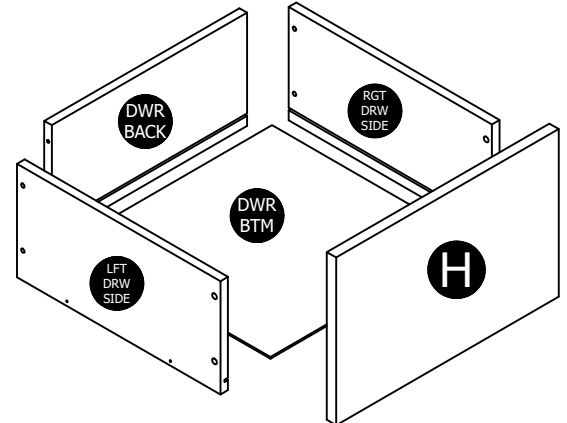
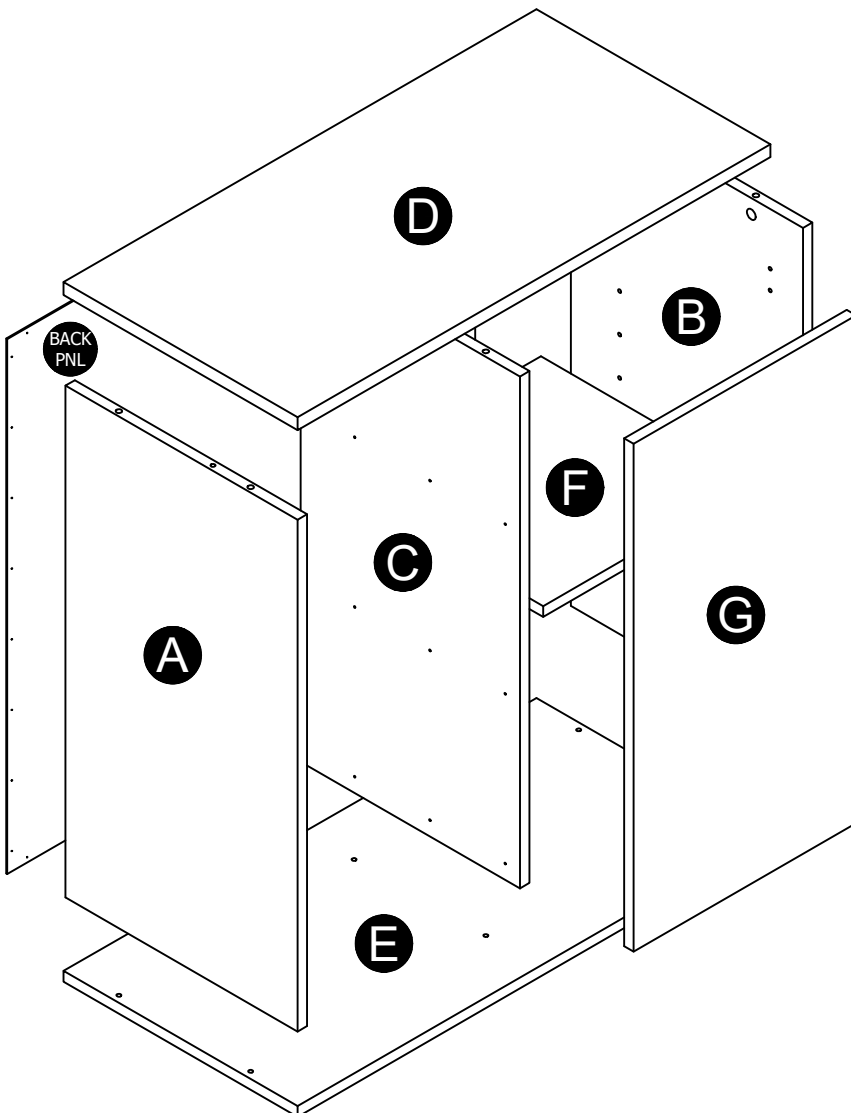

Part List

Actual Size

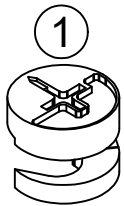

(x6)
#A22700
cam lock

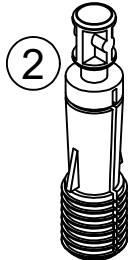

(x6)
#A22710
cam bolt

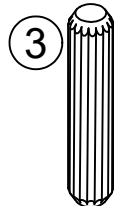

(x3)
#A21670
wood dowel



(x32)
#A21110
nail

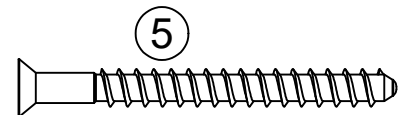

(x6)
#A23030
confirmat screw



(x30)
#A11080
7/16" screw



(x12)
#A14220
1/2" screw



(x8)
#A12105
7/16" screw
(Black)



(x24)
#A12120
7/16" screw

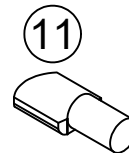

(x4)
#A80250
shelf support

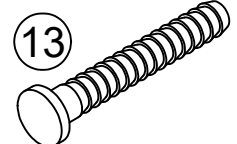

(x12)
#A21975
drive fastener

Not Actual Size

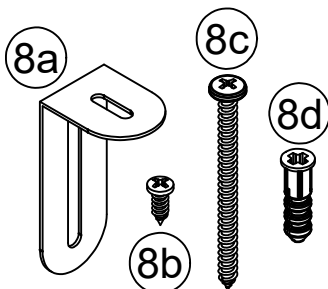

(x1)
#A84050
safety bracket kit

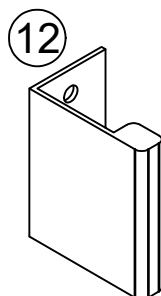

(x4)
#A50580
pull

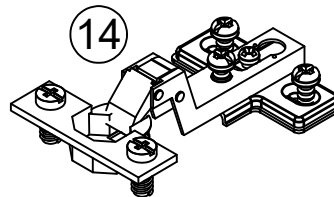

(x2)
#A65640
hinge

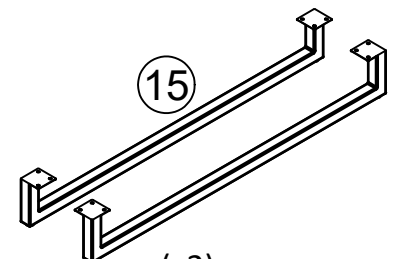

(x2)
#A95490

Part List

Not actual size

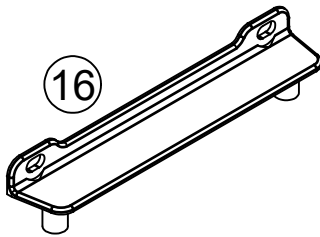

(x6)
#A54520
drawer bracket

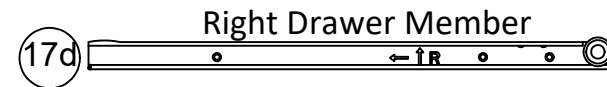
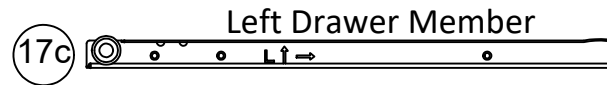

(x3)
17 #A56770
slide

STEP 1

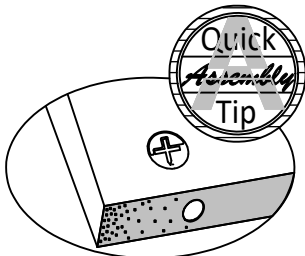
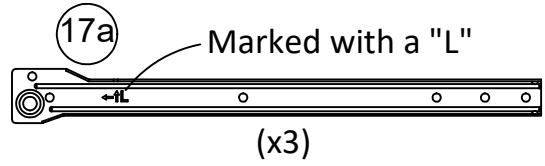
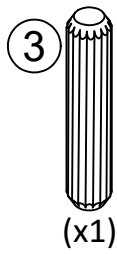
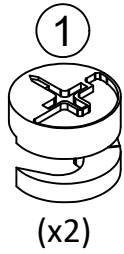
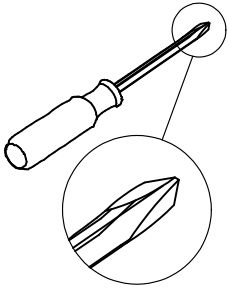

Proper orientation of CAM LOCK

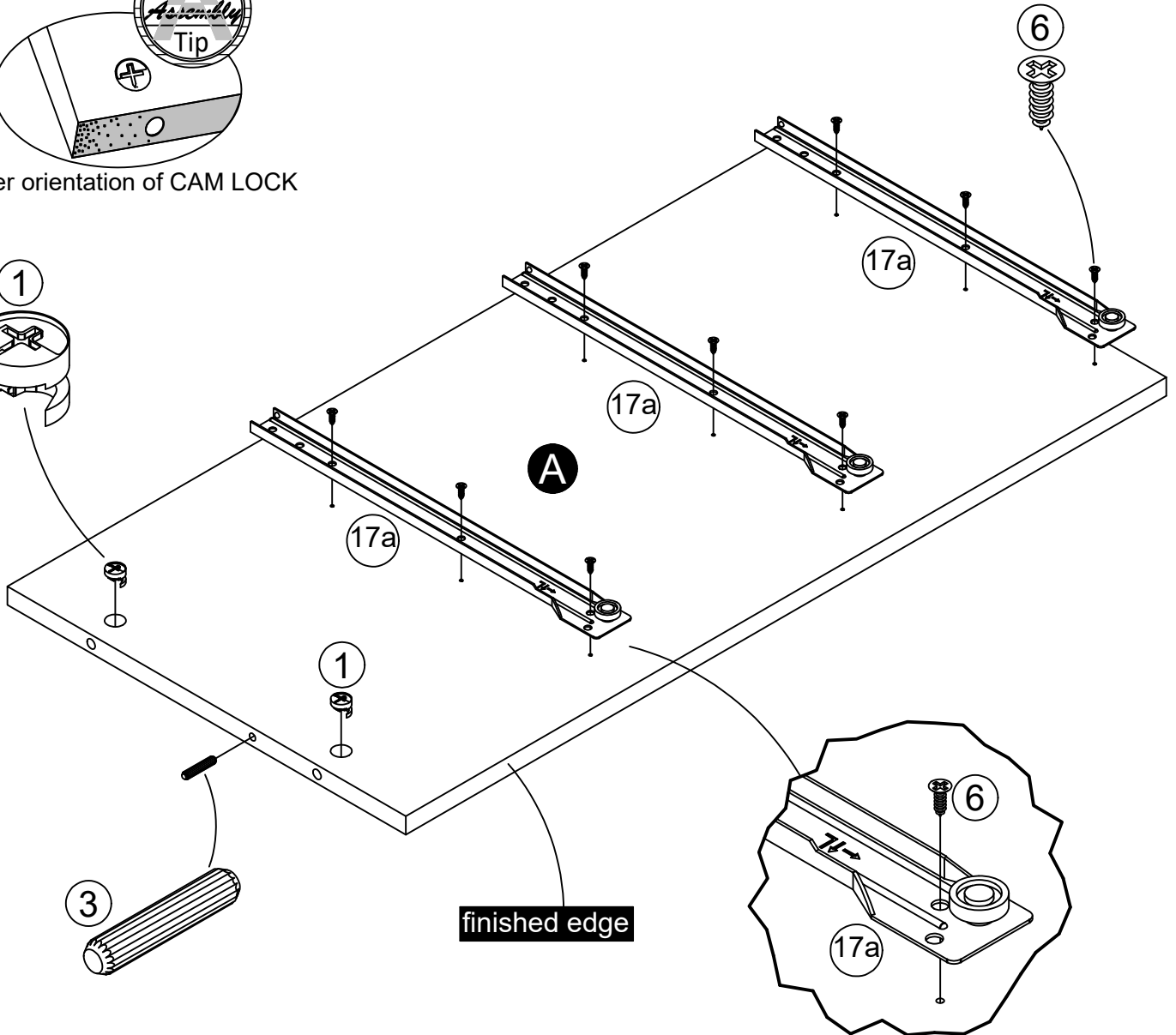
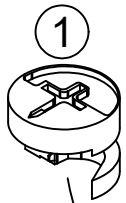

STEP 2

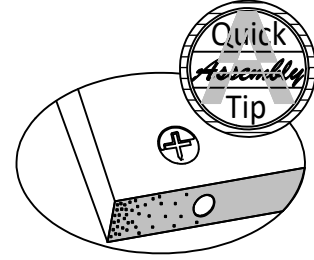
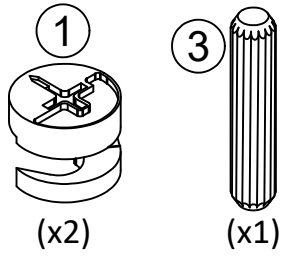

Proper orientation of CAM LOCK

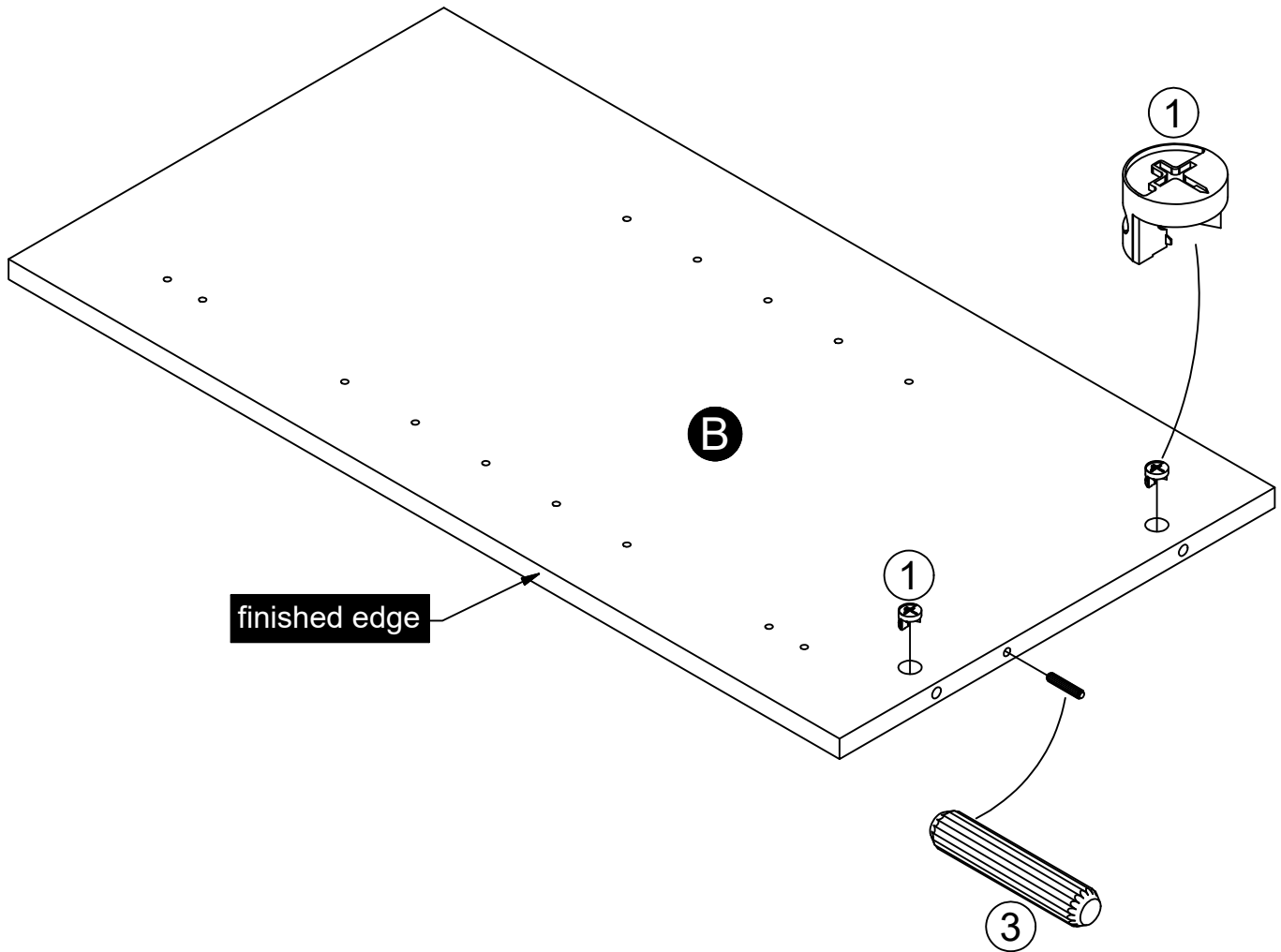

STEP 3

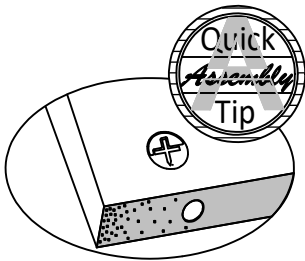
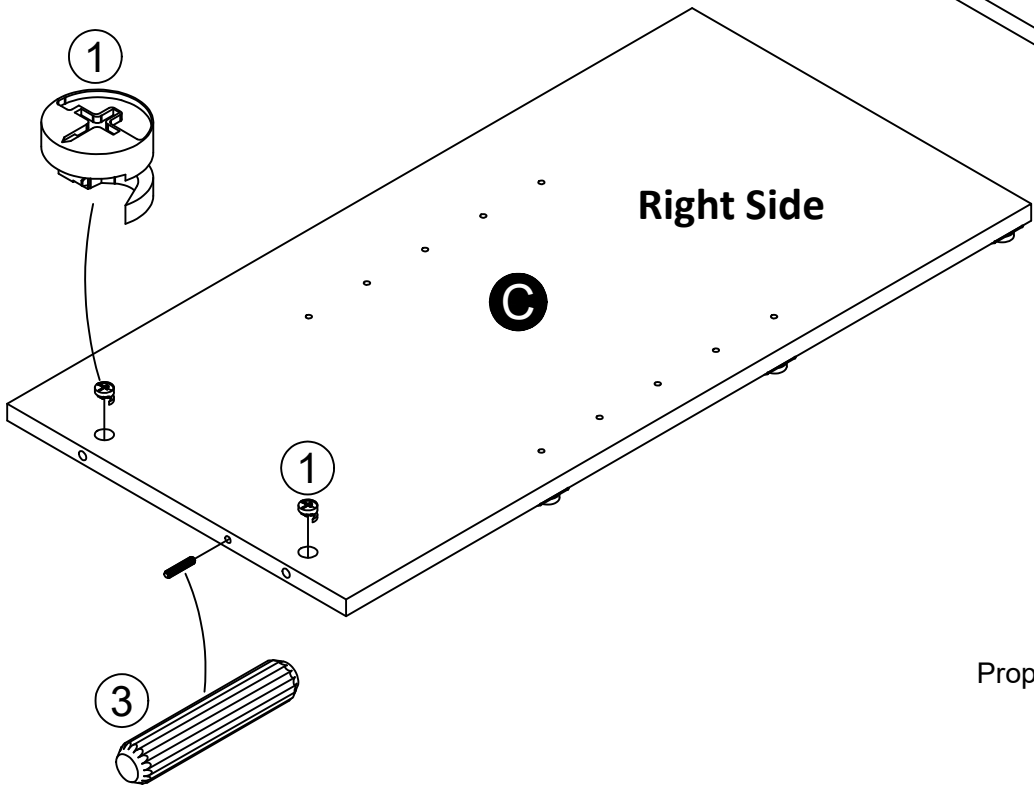
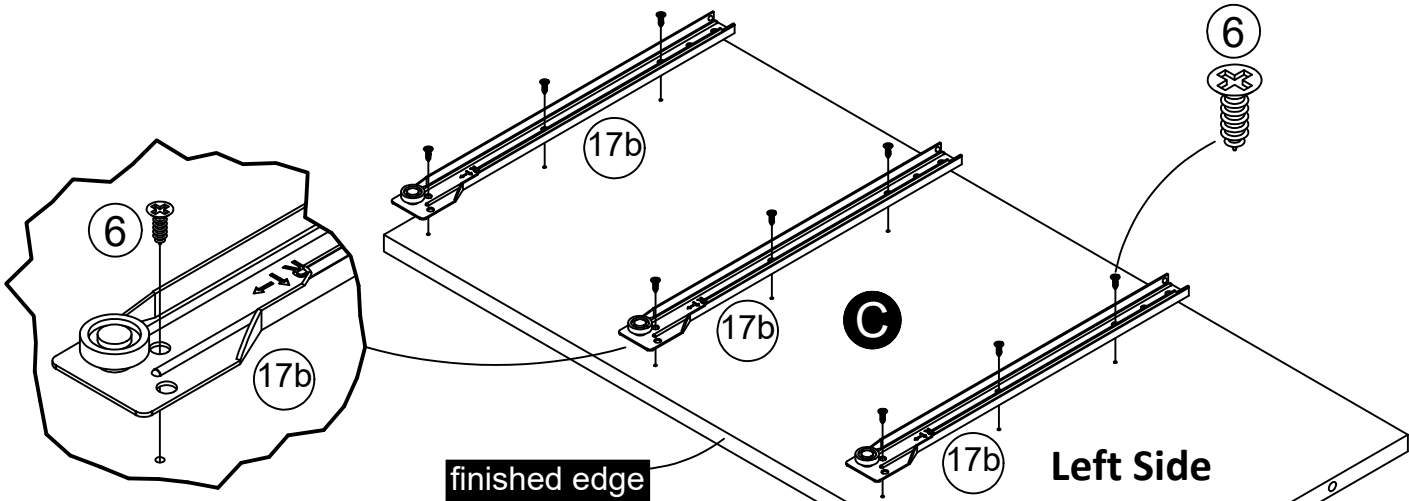
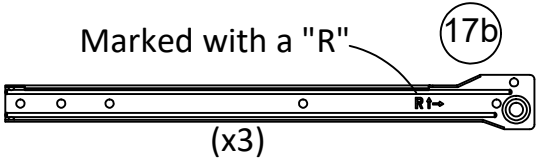
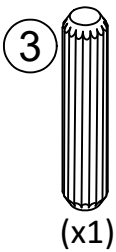
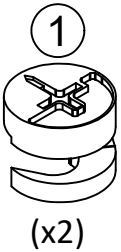
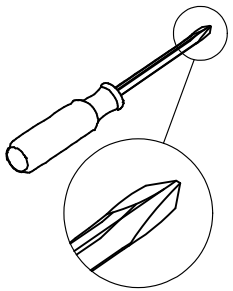

STEP 4

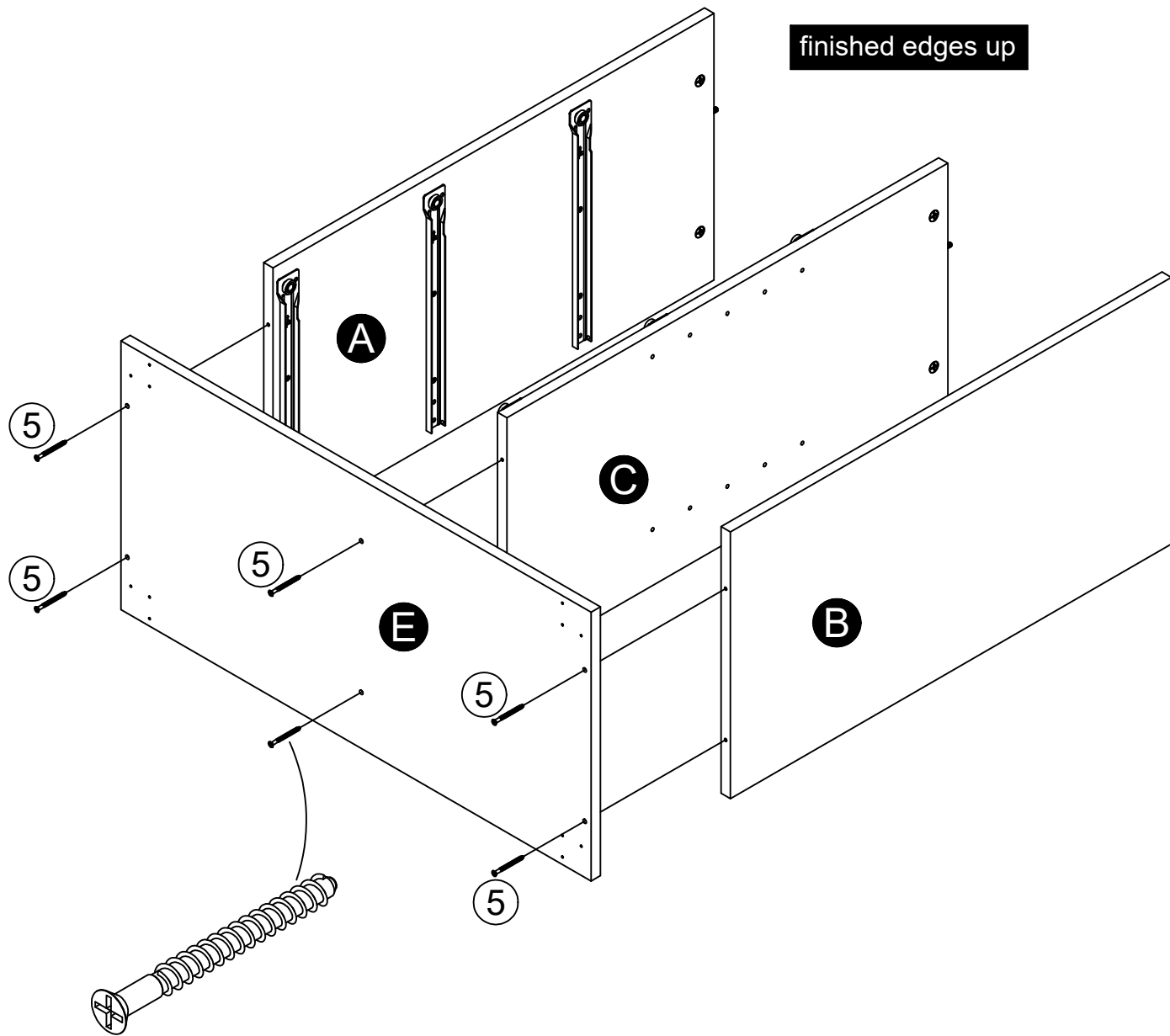
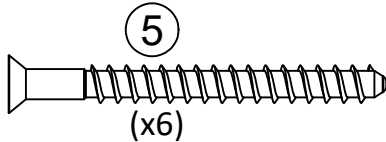
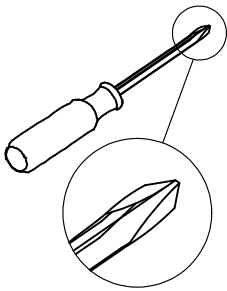

STEP 5

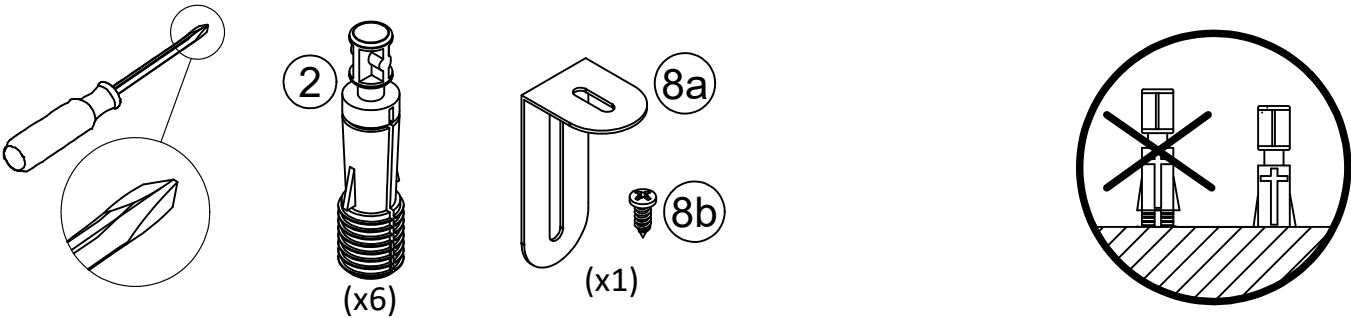

Do not fully tighten screw.

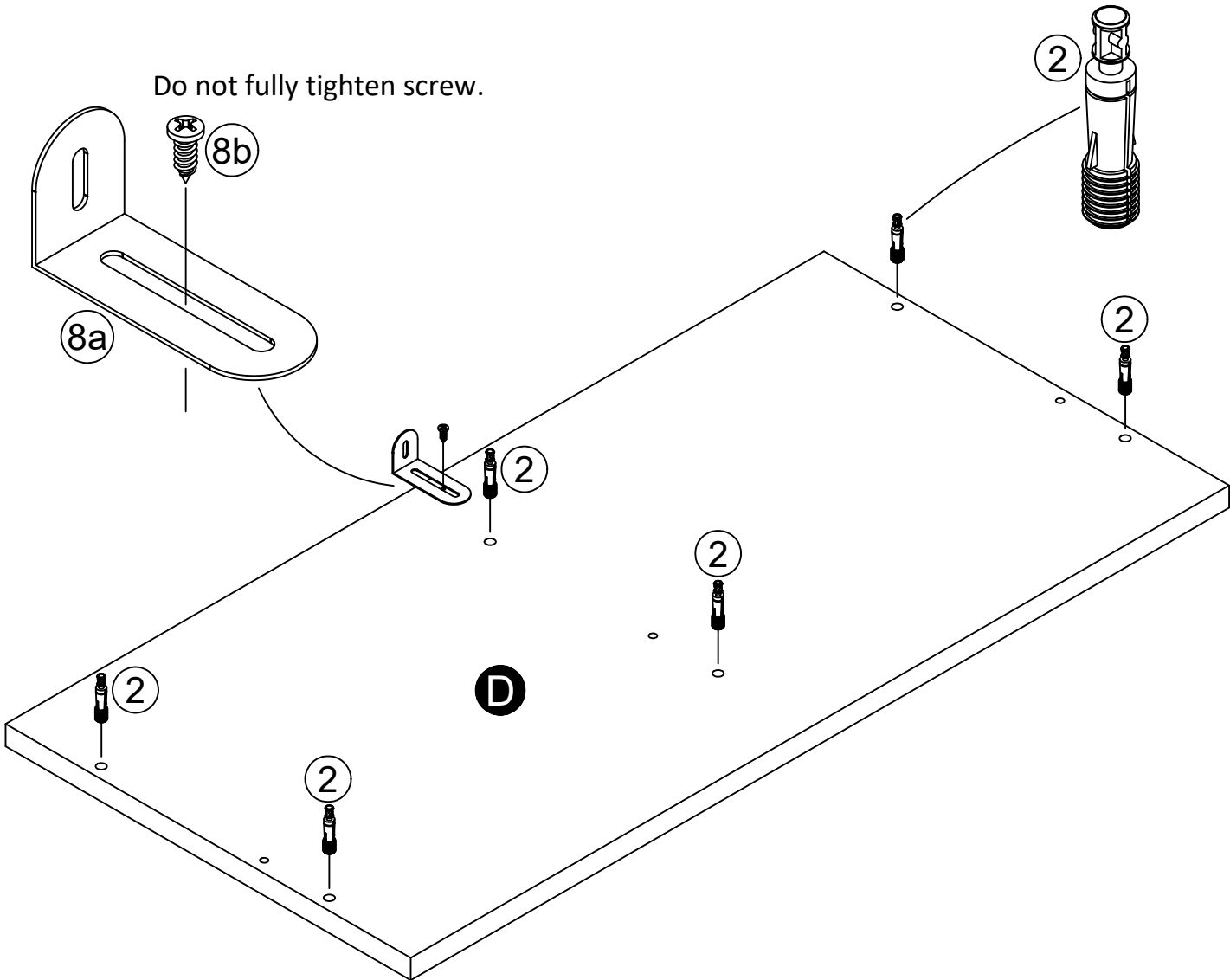

STEP 6

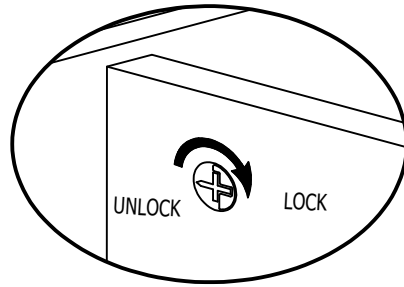
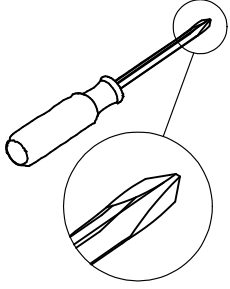

finished edges up

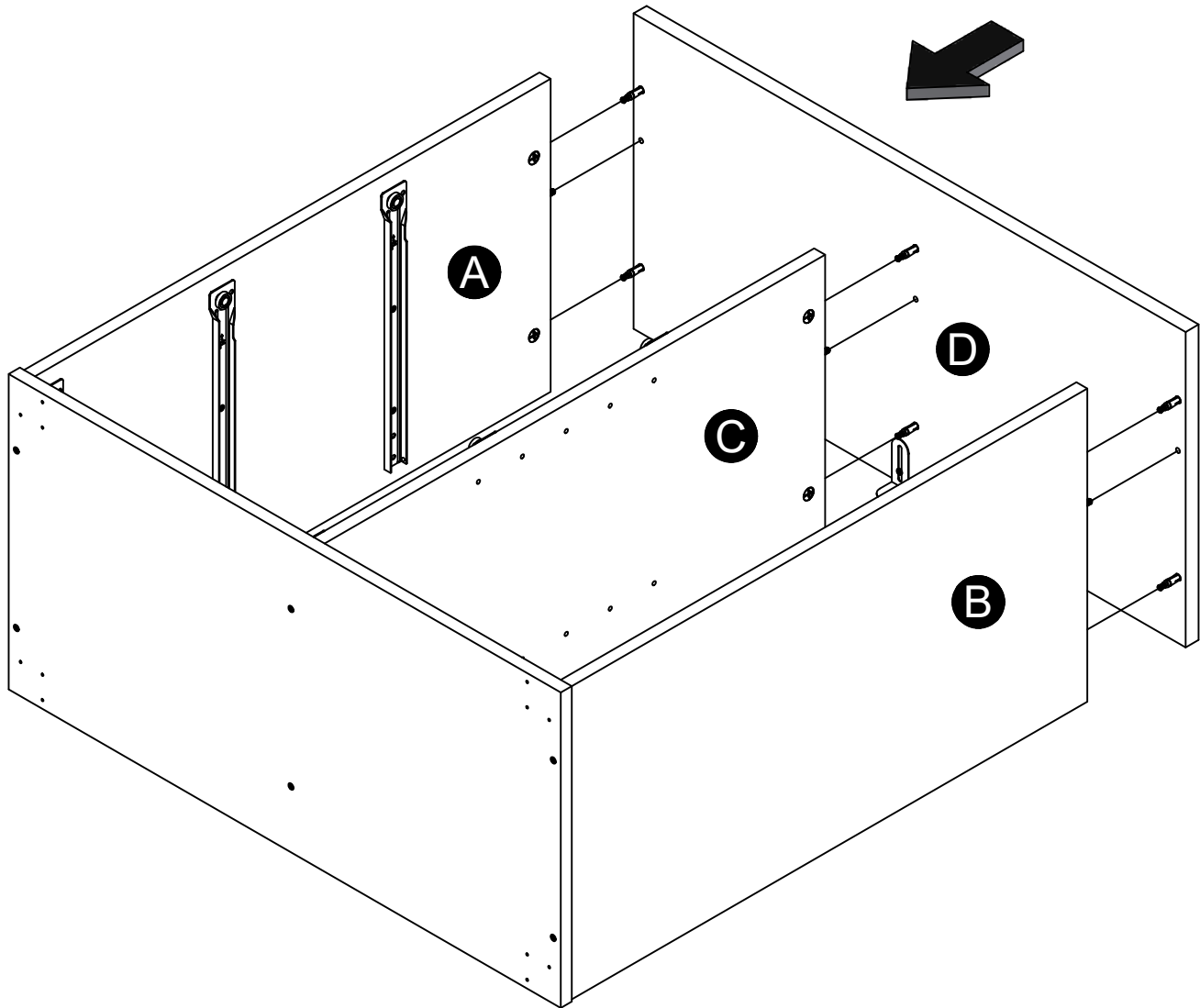

STEP 7

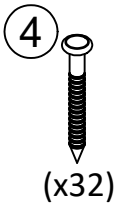

IMPORTANT! THE BACK PANEL IS A STRUCTURAL PART OF THIS UNIT AND MUST BE INSTALLED PROPERLY.

Carefully turn the unit over on its front surface as shown. Attached the back panel as shown nailing straight into the raw edges. Assure that the unit is square. Distance from corner to corner must be equal as shown.

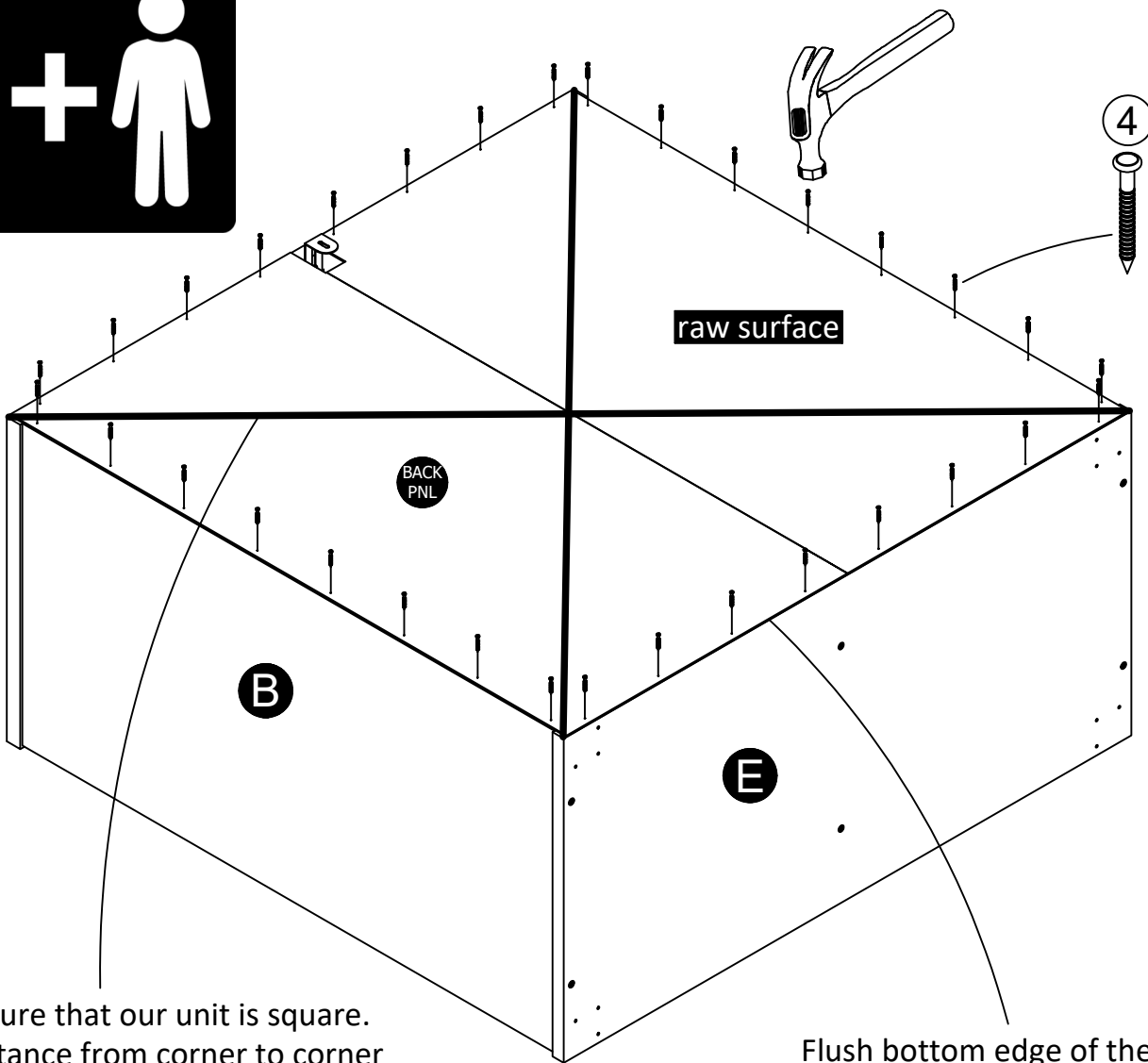
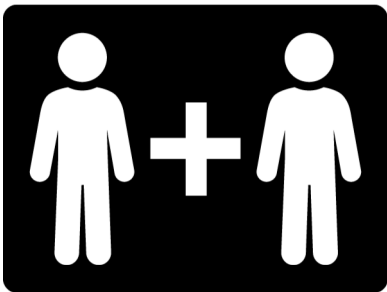

Assure that our unit is square. Distance from corner to corner must be equal as shown.

Flush bottom edge of the back panel with the bottom edge of bottom (E).

STEP 8

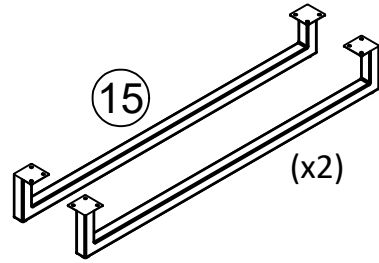
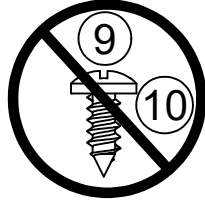
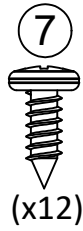
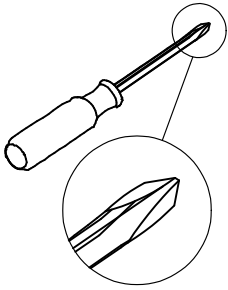

Do not get screws #7 and #9 / 10 mixed up. Screw #7 has a larger head and body.

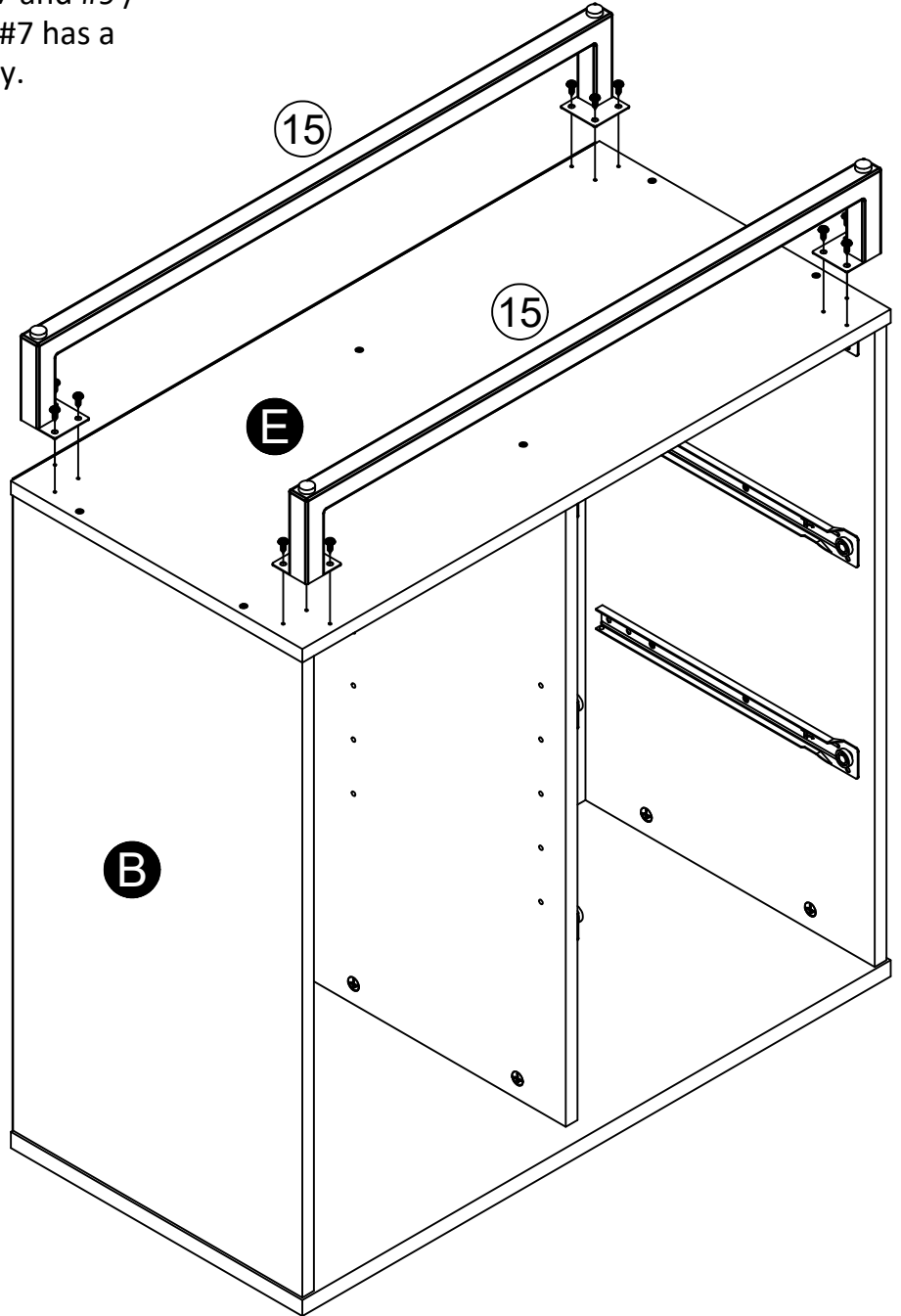
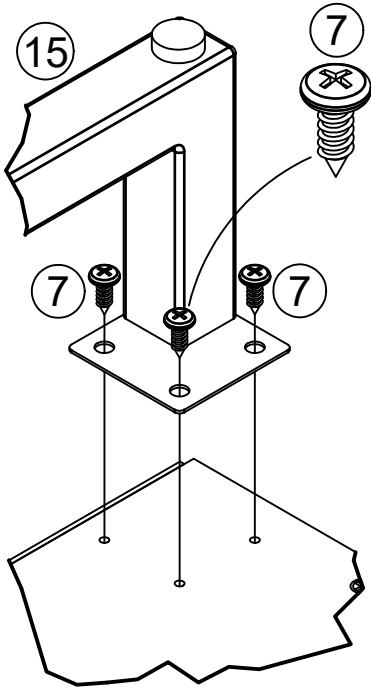

STEP 9

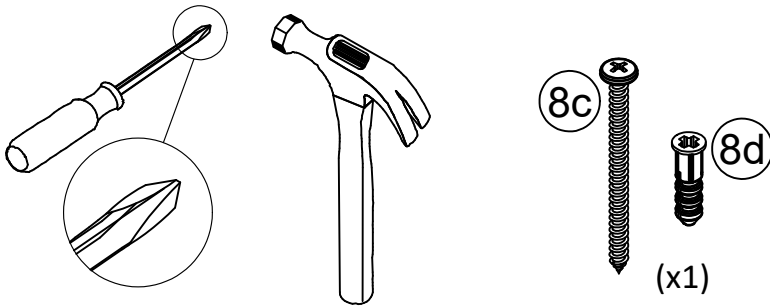

For Masonry, Concrete, or other wall materials:

Consult your local hardware store for appropriate anchors to securely attach the safety bracket.

IMPORTANT: THIS UNIT MUST BE SECURE TO THE WALL TO HELP PREVENT TIPOVER. FOLLOW THESE INSTRUCTIONS TO INSTALL THE ANTI-TIPPING SAFETY BRACKET PROVIDED WITH THIS PRODUCT.

WARNING

Serious or fatal crushing injuries can occur from furniture tipover.

To prevent tipover:

- * Install tipover restraint provided
- * Place heaviest items in the lowest drawers
- * Unless specifically designed to accommodate, do not set TVs or other heavy objects on the top of this product
- * Never allow children to climb or hang on drawers, door, or shelves
- * Never open more than one drawer at a time

Use of tipover restraints may only reduce, but not eliminate the risk of tipover

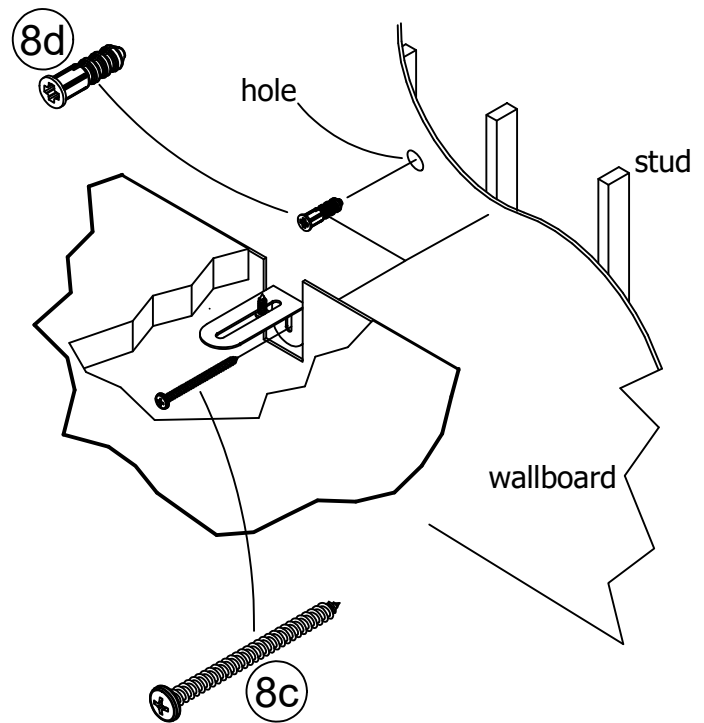

OPTION 1: Attachment into a wall stud (preferred method)

Using a stud finder, locate a stud in the wall. Place your unit against the wall, with the safety bracket aligned in this location. To make driving the screw easier, you can drill a 1/8" diameter pilot hole (3mm) through the safety bracket into the stud. Drive the screw through the safety bracket into the wall stud. Tighten the screw that was not fully tightened in step 5.

OPTION 2: Attachment into drywall

Locate your unit where desired against a wall and mark the wall through the safety bracket, then move your unit aside. Drill a 3/16" diameter hole (5mm) into the wallboard. Tap the wall anchor into the hole until it is flush. Move your unit into location and fasten the wall bracket to the wall anchor with the screw. Tighten the screw that was not fully tightened in step 5.

STEP 10

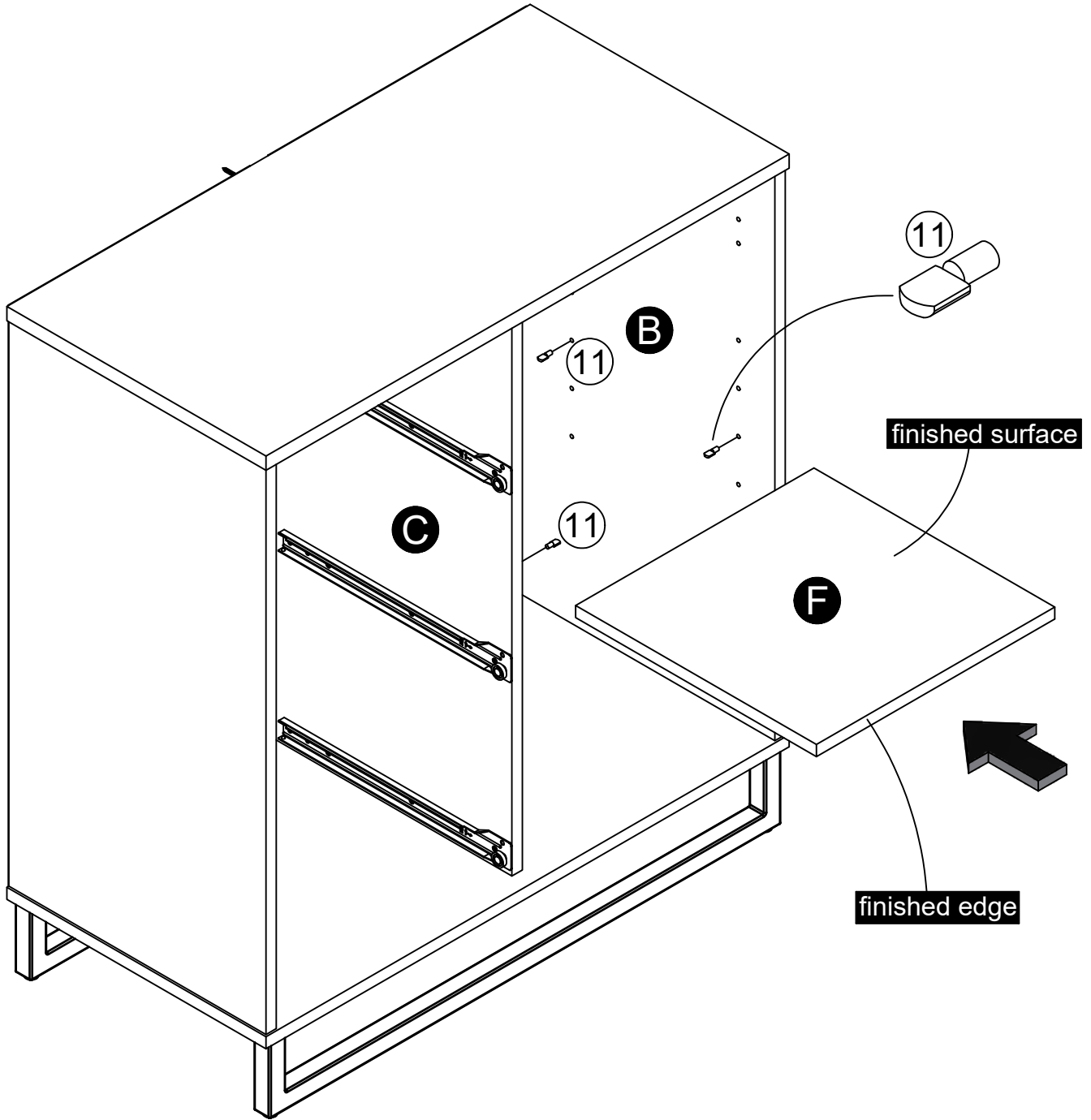
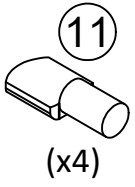

STEP 11

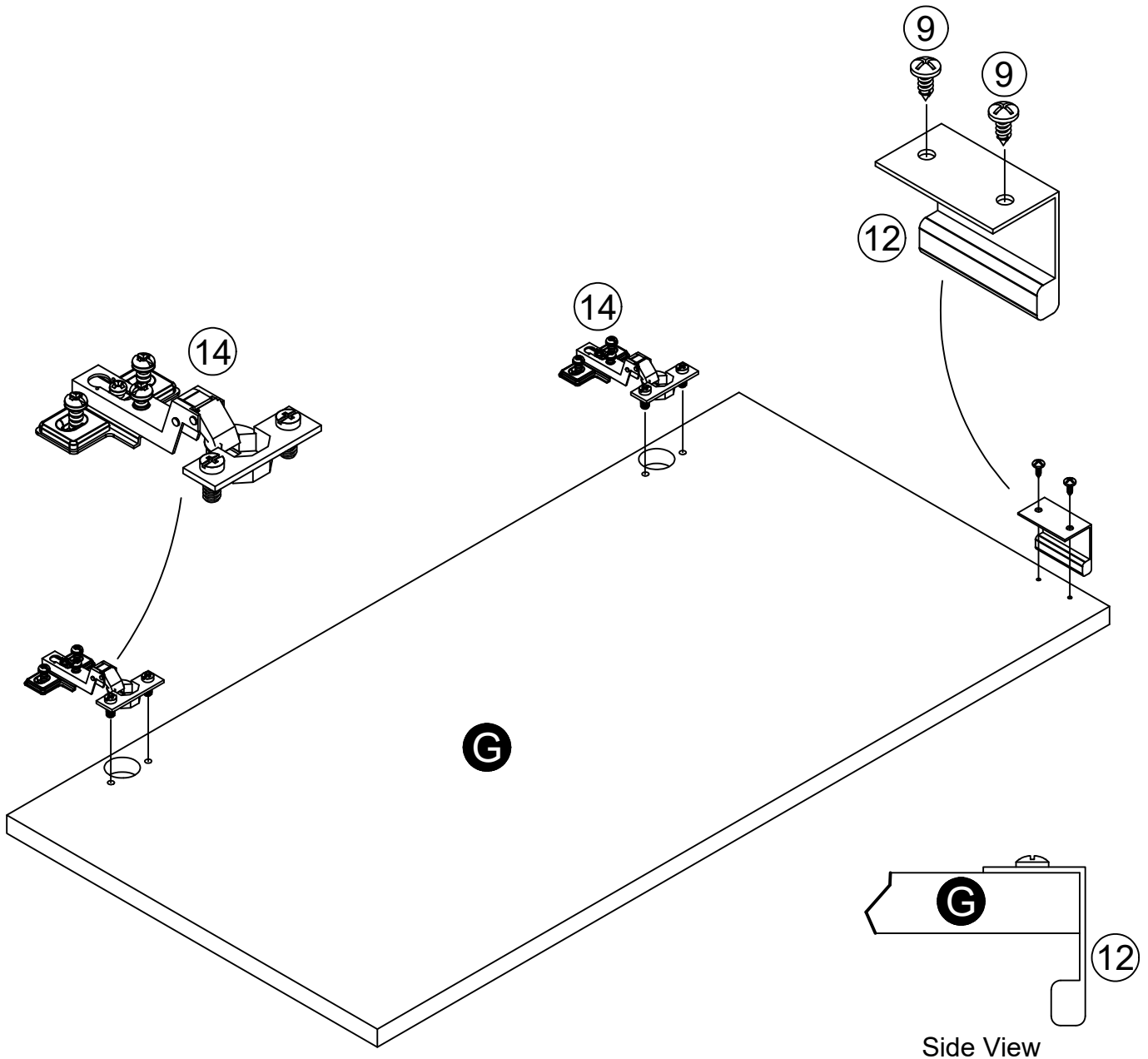
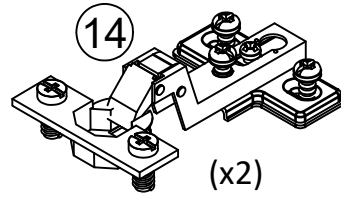
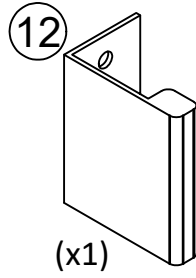
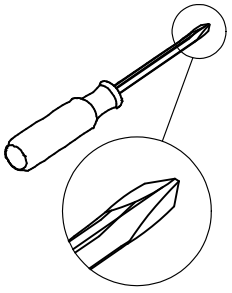

STEP 12

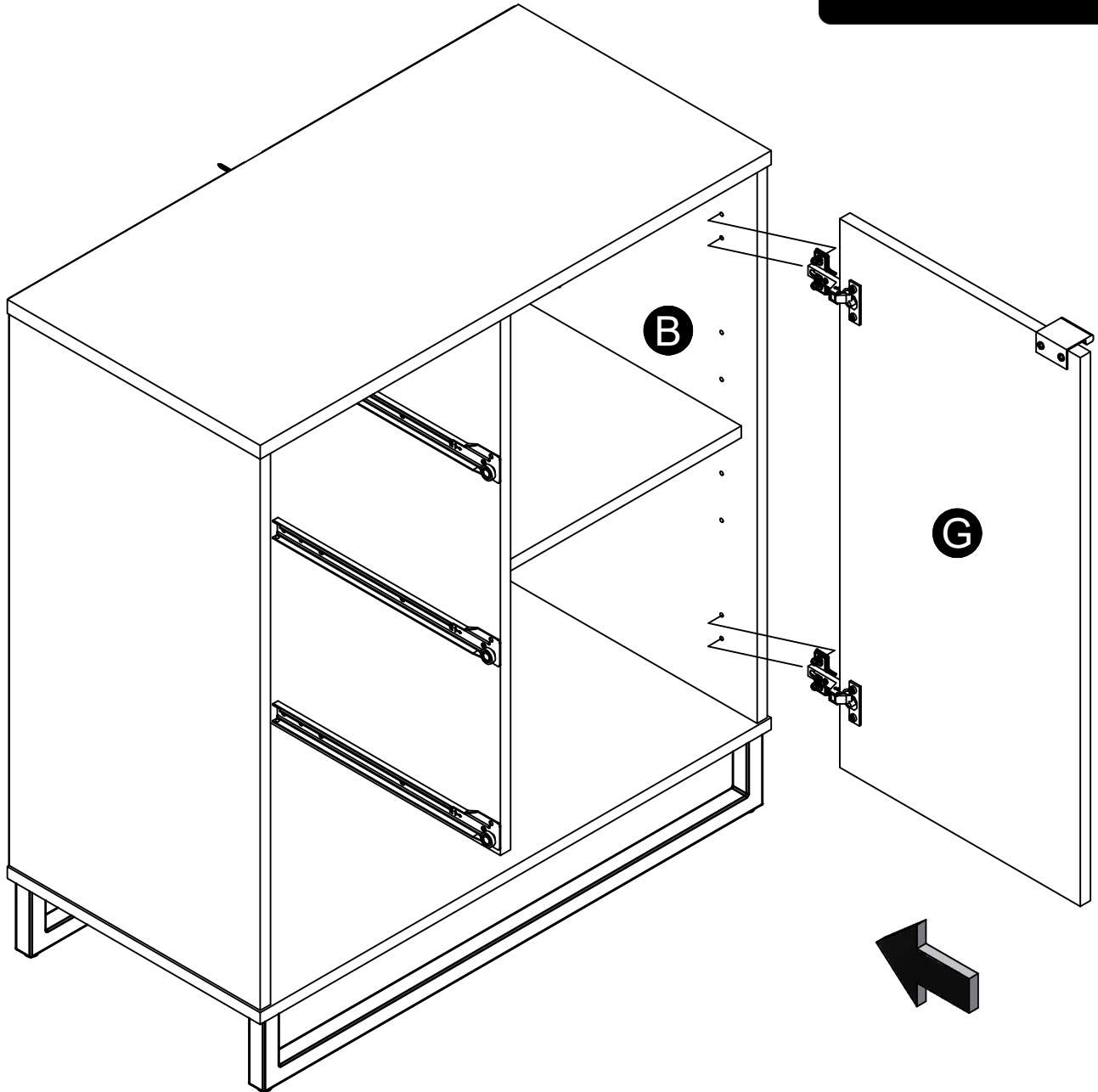
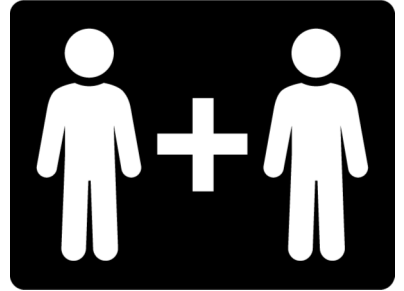
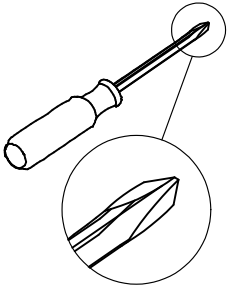

STEP 13

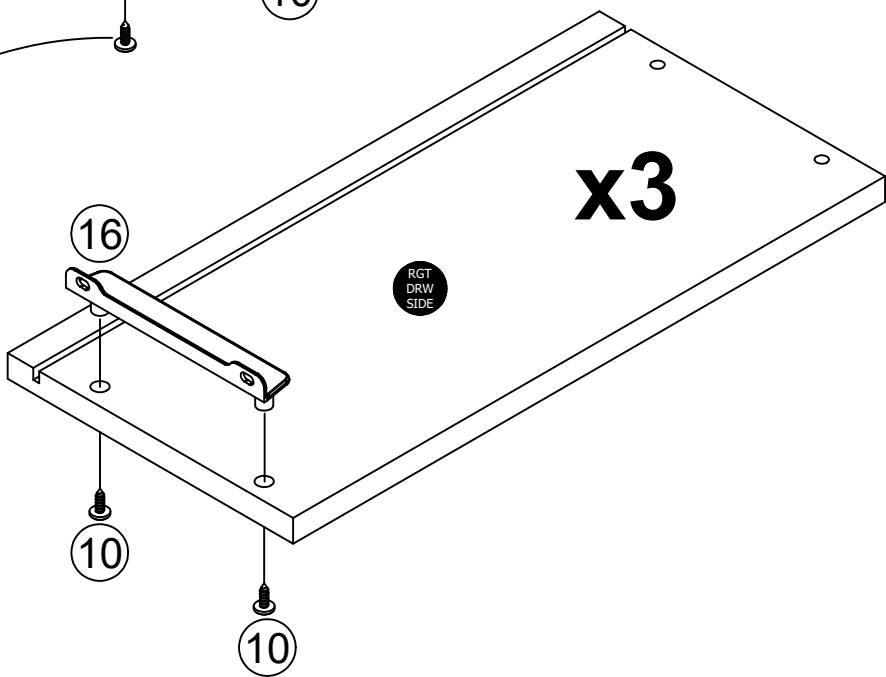
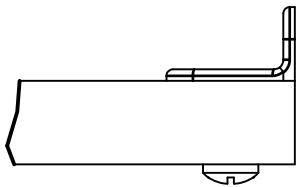
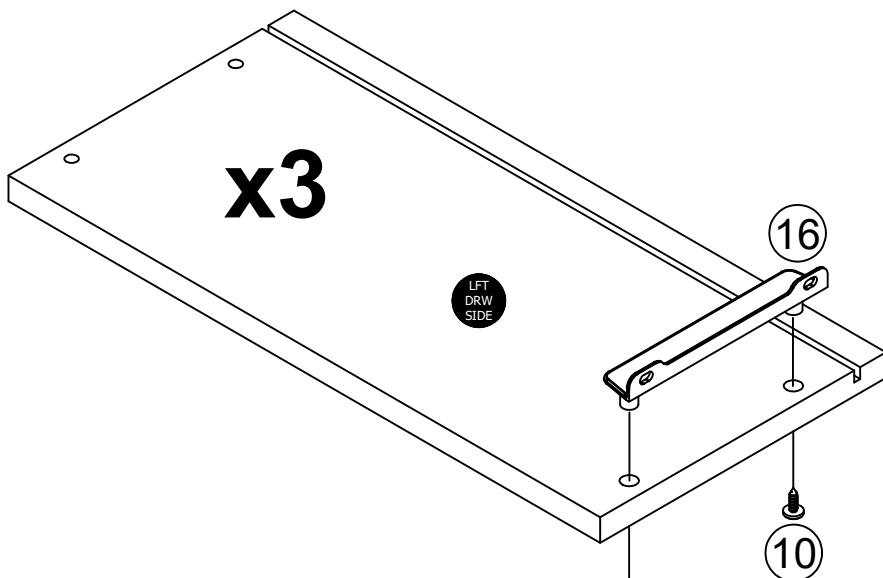
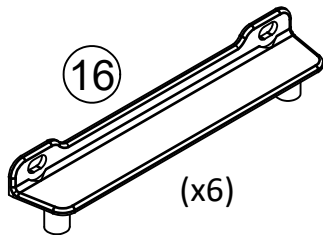
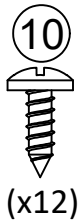
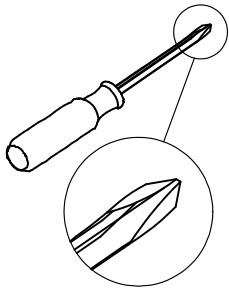

STEP 14

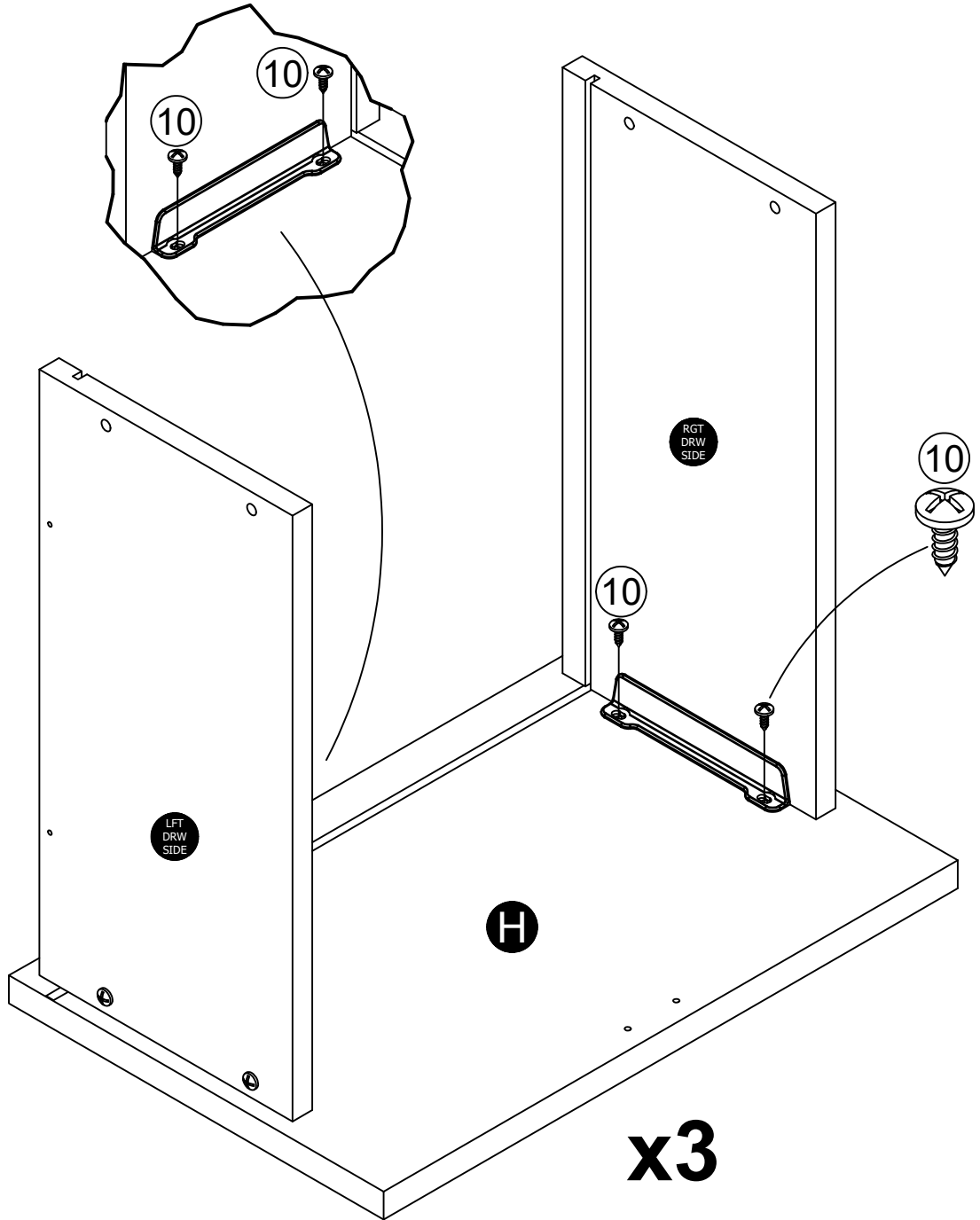
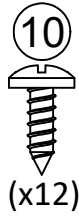
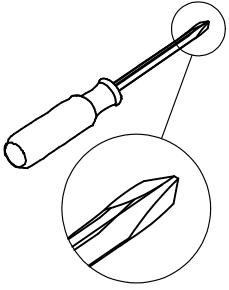

STEP 15

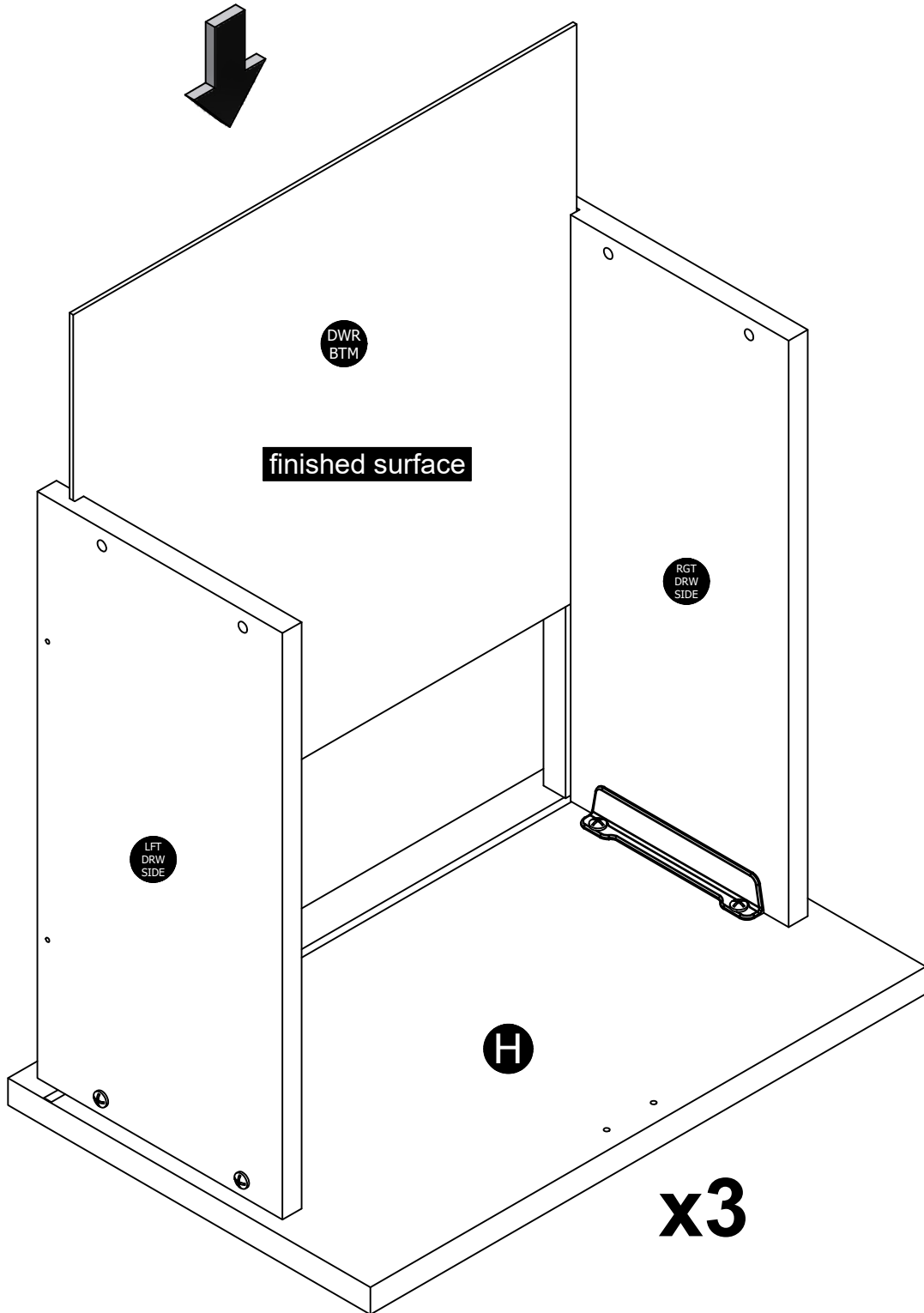

STEP 16

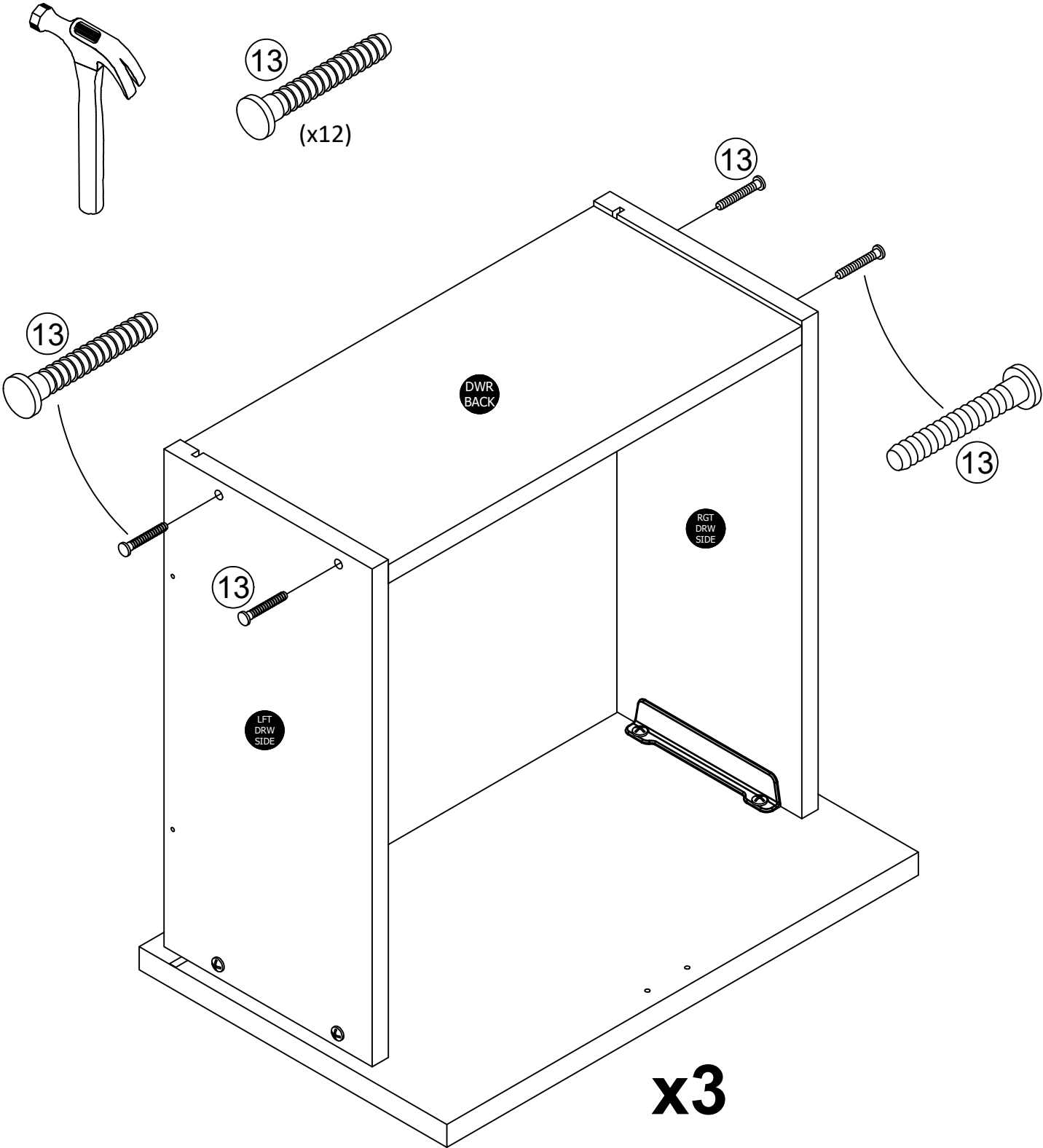

STEP 17

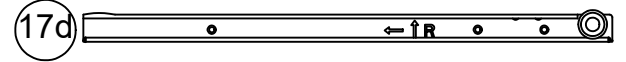
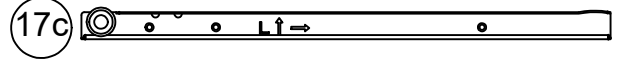
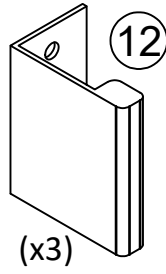
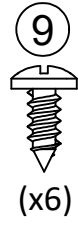
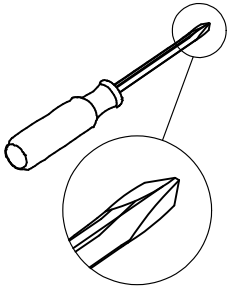

(x3)

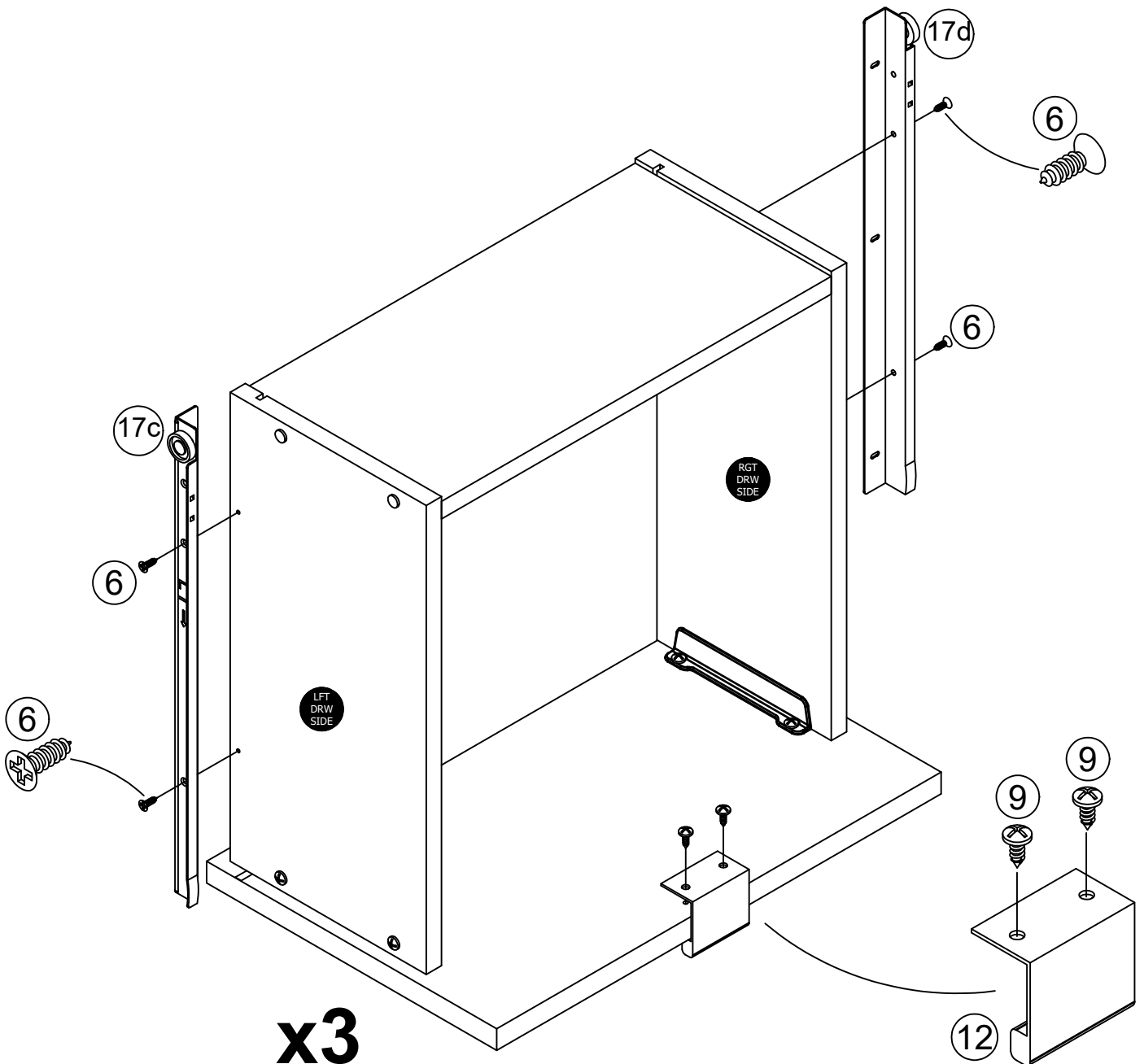

x3

STEP 18

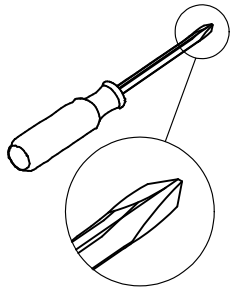

Note: The drawer bracket holes are slotted. Drawer fronts can be adjusted by loosening screws, making needed adjustments and retightening screws.

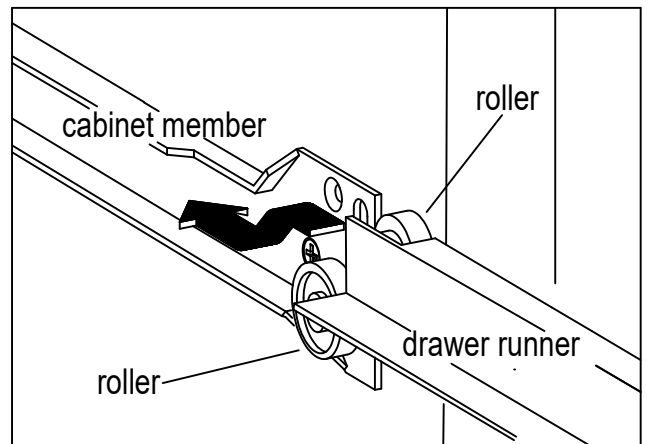
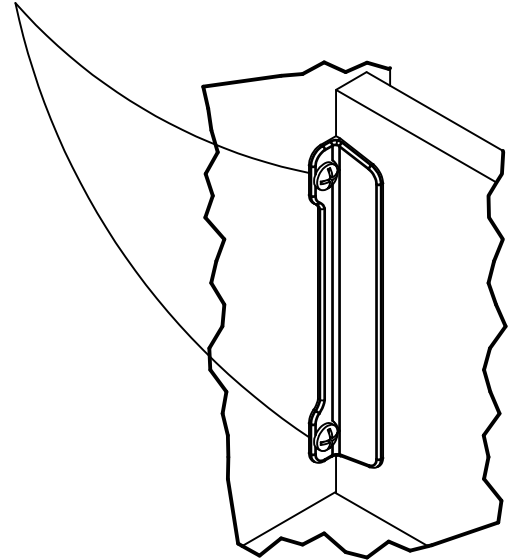
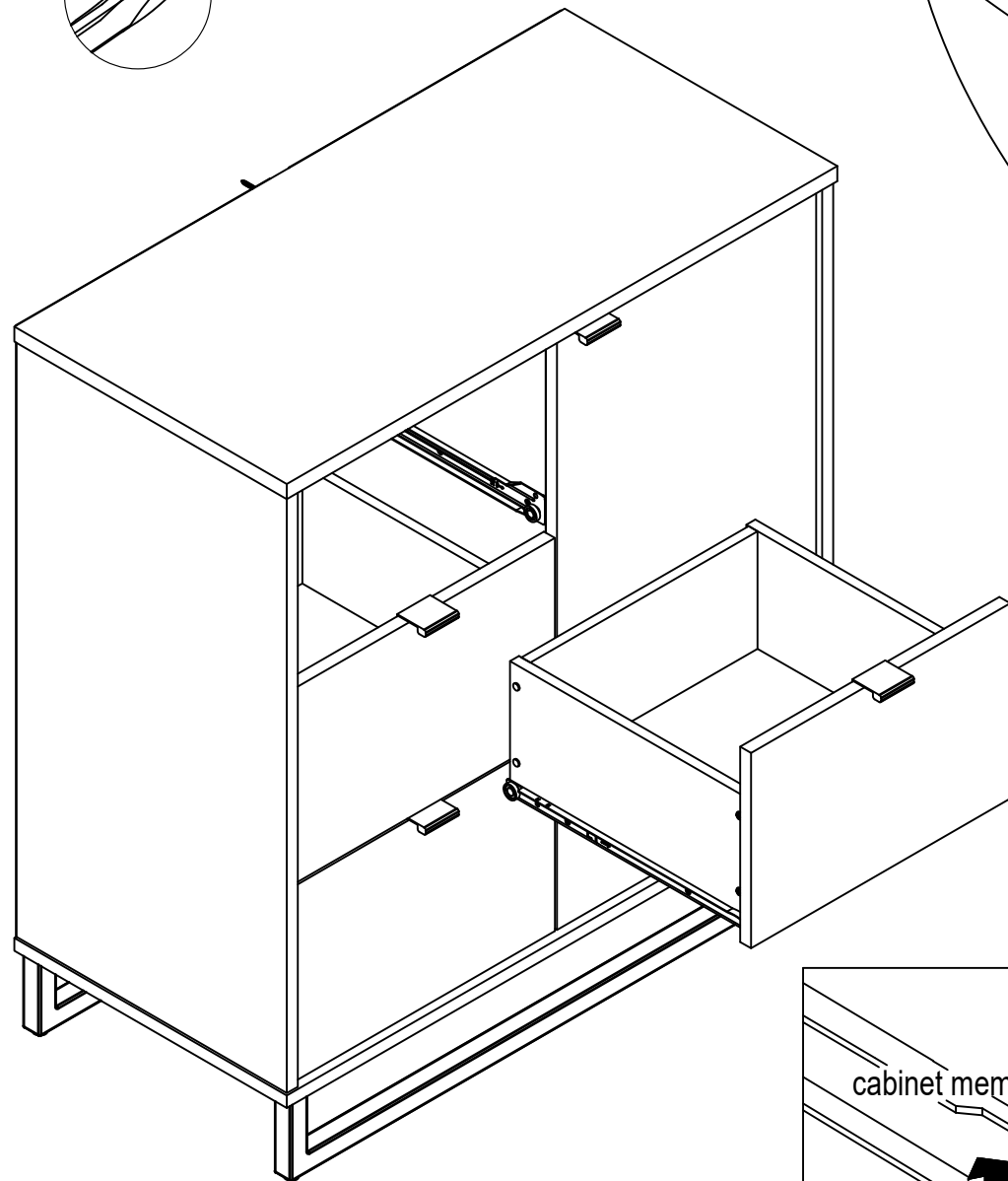

STEP 19

Door Adjustment

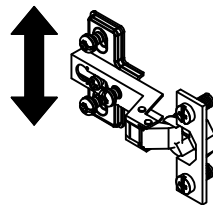
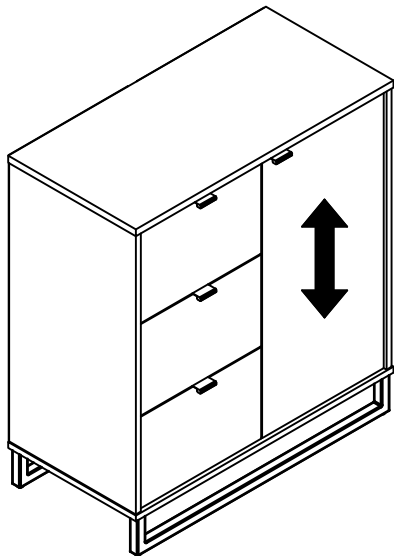
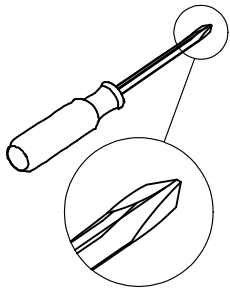

To adjust the vertical height:
Loosen the screws "A" on both hinges. They are usually in slotted holes which allows you to adjust up or down by a few mm. Then tighten back up.

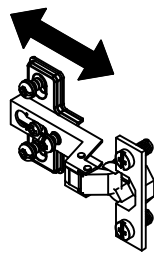
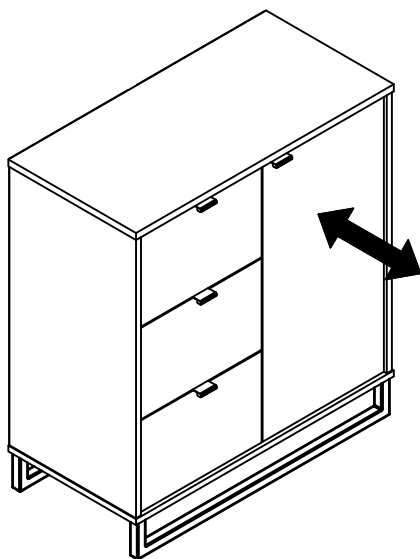
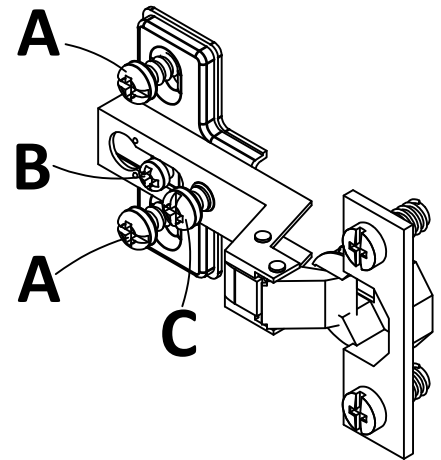

To adjust the depth:
Loosen the screw "B" and adjust door.

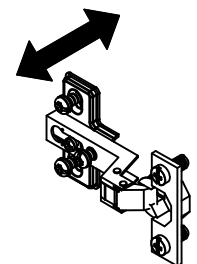
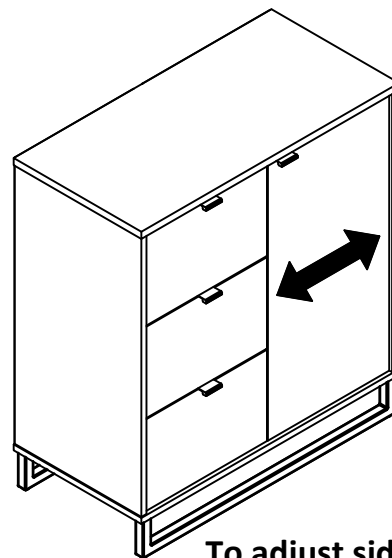

To adjust side to side:
Loosen the screw "C" on BOTH hinges and tighten "B" moves door outward. Loosen "B" and tighten "C" moves doors inward.

Maximum Loads

This unit has been designed to support the maximum loads shown. Exceeding these load limits could cause sagging, instability, product collapse, and/or serious injury.

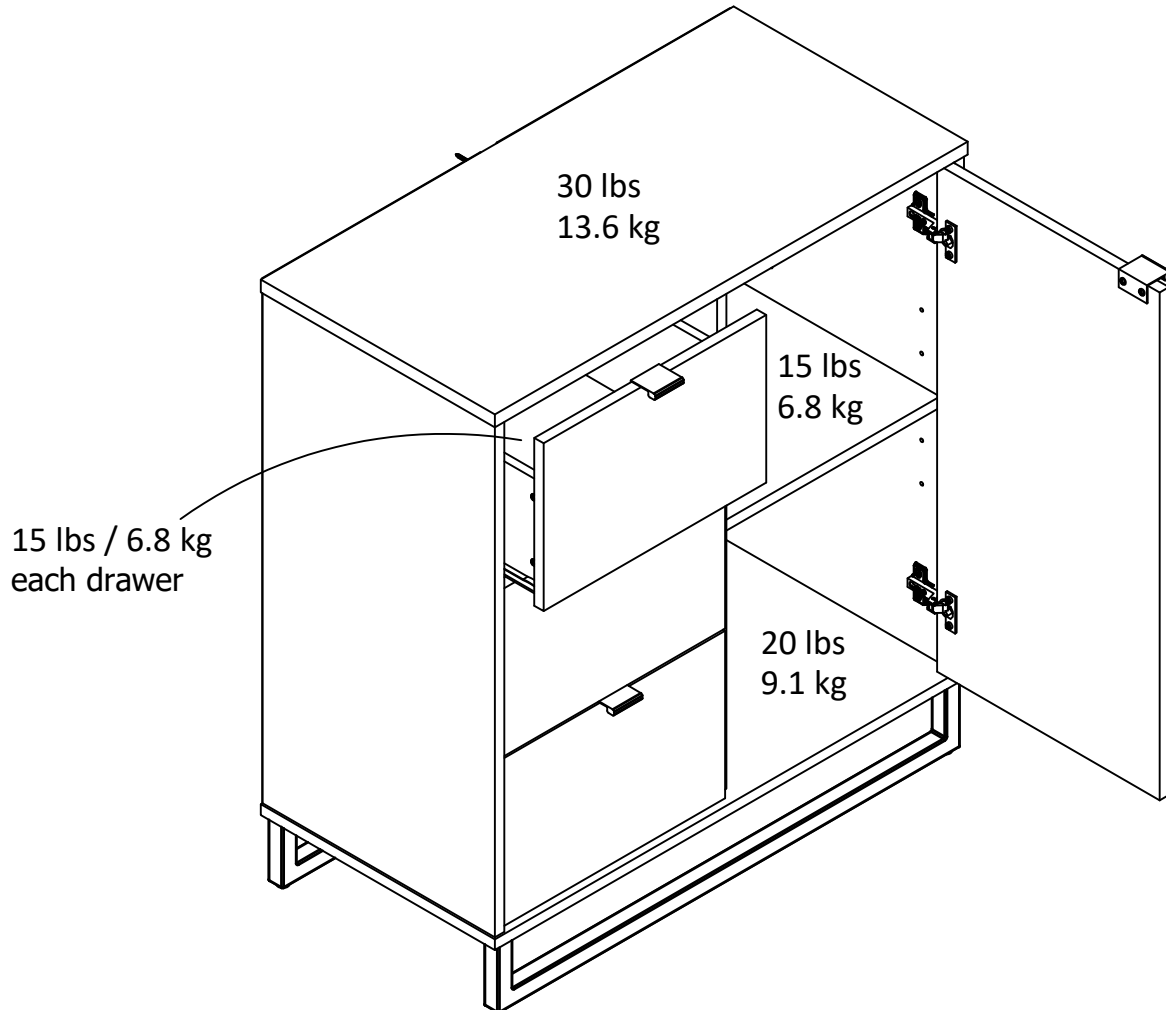

Warning: Risk of injury to persons - do not place a television on this furniture. This furniture is not approved for use with a television.

Certificate of Conformity

1. This certificate applies to the Dorel Home Furnishings, Inc. product identified by this instruction manual.
2. This certificate applies to compliance of this product with the CPSC Ban on Lead-Containing Paint (16 CFR 1303).
3. This product is distributed by: Dorel Home Furnishings, Inc.
410 East First Street South
Wright City, MO 63390
636-745-3351
4. Site of Manufacture: Tiffin OH
5. See front page of instruction manual for date of manufacture.

Register your product to receive the following:



- * New trend details - sneak peek on what's new
- * Surveys - have a voice within our community
- * Exclusive deals and discount codes
- * Quick and easy replacement part service

To register your product, visit ameriwoodhome.com

5 Star Rating



Visit your local retailer's website, rate your purchased product and leave us some feedback!

We would like to extend a big "Thank You" to all of our customers for taking the time to assemble this Ameriwood Home product, and to give us your valuable feedback.

*Thank
You!*

Cubierta Delantera

Este libro de instrucciones contiene información **IMPORTANTE** de seguridad. Por favor lea y manténgalo para referencia en el futuro.

No Regrese este producto! Comuníquese con nuestro amistoso equipo de servicio al cliente para obtener ayuda.

Llámenos al: 1-800-489-3351 (Gratis) Lunes - Viernes 9am - 5pm CST

Visitar: www.ameriwoodhome.com

PRECAUCION

Este mueble puede volcarse y causar graves heridas y/o muerte.

Anclar el mueble a un poste de madera en la pared (si esto se requiere).

No Permita que los niños monten el mueble.

Mantenga los artículos más pesados en los cajones de abajo.

Consejos Útiles (página 2)

- Abra su artículo en el área donde usted planea utilizarlo para evitar levantar y moverlo menos
- Identificar, ordenar y contar las piezas antes de intentar ensamblar
- Las clavijas de compresión se golpean con un martillo
- Las diapositivas están marcadas con una R (derecha) y L (izquierda) para la colocación correcta
- Asegúrese de que siempre este el punto localizado en la parte superior de bloqueador de leva este volteado hacia borde exterior
- Utilizar todos los clavos para el panel de atrás y distribuirlos por igual
- El panel de atrás debe utilizarse para asegurarse de que la unidad quede fija y firme
- No use químicas fuertes ni limpiadores abrasivos en este artículo
- Nunca empuje, tire ni arrastre los muebles

Antes de Que Empieces (página 3)

- Lea cuidadosamente cada paso y siga el orden correcto
- Separar y contar todas sus piezas y hardware
- Dése suficiente espacio para el proceso de ensamble
- Tenga las siguientes herramientas: destornillador de cabeza plana, #2 cabeza Phillips
Destornillador y martillo
- Precaución: Si usa un taladro electrónico o un destornillador eléctrico para atornillar, por favor asegúrese que deje de atornillar cuando el tornillo este apretado. Fallar hacer esto puede causar barrer el tornillo.

Sistema de fijar el bloqueo de leva (página 3)

Esta sistema de fijar el bloqueo de leva sera usado en todo el proceso ensamble.

Página 11

Lado izquierdo Lado derecho

Página 13

No ajuste del todo el tornillo.

Página 15

¡IMPORTANTE! EL PANEL TRASERO ES UNA PARTE ESTRUCTURAL DE ESTA UNIDAD Y DEBE INSTALARSE CORRECTAMENTE.

Vuelva la unidad sobre su superficie delantera, como se ve.

Ensamble el panel trasero como se ve clavándolo directamente sobre los bordes rugosos.

Asegúrese de que la unidad está a escuadra.

La distancia entre ambas esquinas debe ser igual, como se ve.

Asegúrese de que nuestra unidad está a escuadra.

La distancia entre ambas esquinas debe ser igual, como se ve.

Ubique el borde inferior del panel trasero al ras con el borde inferior de la parte inferior (E)

Página 16

No se confunda los tornillos Nº 7 con los Nº 9 y 10. El tornillo Nº 7 tiene una cabeza y vástago más grandes.

Página 17

Para mampostería, hormigón y otros materiales de pared:

Consulte en su ferretería local qué anclajes son adecuados para fijar correctamente el soporte de seguridad.

¡IMPORTANTE: ESTA UNIDAD DEBE ESTAR ASEGURADA A LA PARED PARA AYUDAR A EVITAR QUE VUELQUE. SIGA ESTAS INSTRUCCIONES PARA INSTALAR EL SOPORTE DE SEGURIDAD ANTIVUELCOS INCLUIDO EN ESTE PRODUCTO.

ADVERTENCIA

Al volcarse un mueble, puede causar lesiones de aplastamiento graves o mortales.

Para evitar vuelcos:

- Instale el soporte antivuelco incluido
- Ubique los artículos más pesados en los cajones de más abajo.
- A menos que esté específicamente diseñado para soportarlos, no instale televisores u otros objetos pesados en la parte superior de este producto.
- Jamás permita que los niños se trepen o se cuelguen de los cajones, la puerta o los estantes.
- No abra más de un cajón a la vez.

El uso de soportes antivuelco puede reducirlo, pero no elimina el riesgo de vuelcos.

Página 17

OPCIÓN 1: Fijación a una viga en la pared (método preferido)

Usando un dispositivo para encontrar vigas, encuentra una viga en la pared. Coloque su unidad contra la pared, con el soporte de seguridad alineado con esta ubicación. Para facilitar la colocación de los tornillos, puede hacer agujeros guía de 1/8 de pulgada (3 mm) a través del soporte de seguridad hasta la viga. Instale el tornillo con el soporte de seguridad en la viga de la pared. Ajuste el tornillo que no quedó totalmente apretado en el paso 5.

OPCIÓN 2: Fijación a una pared de paneles de yeso

Ubique su unidad en el lugar deseado contra la pared y marque la pared a través del soporte de seguridad, luego retire la unidad. Perfore un agujero de 3/16" (5 mm) en la pared. Martille el anclaje de la pared en el agujero hasta que esté al ras. Coloque su unidad y ajuste el soporte de pared en el anclaje de pared con el tornillo. Ajuste el tornillo que no quedó totalmente apretado en el paso 5.

Página 26

Nota: Los agujeros del soporte de cajón son ranurados. Los frentes de los cajones pueden ajustarse aflojando los tornillos, haciendo los ajustes necesarios y ajustando los tornillos nuevamente.

Página 27

Ajuste de la puerta

Para ajustar la altura vertical:

Afloje los tornillos "A" en ambas bisagras. Generalmente están instalados con agujeros ranurados que permiten elevarlas o bajarlas unos milímetros. Luego ajuste los tornillos nuevamente.

Para ajustar la profundidad:

Afloje el tornillo "B" y ajuste la puerta.

Para ajustar lateralmente:

Al aflojar el tornillo "C" en AMBAS bisagras y ajustar el tornillo "B", la puerta se mueve hacia afuera. Al aflojar el "B" y ajustar el "C", la puerta se mueve hacia dentro.

Página 28

CARGA MAXIMA

Esta unidad ha sido diseñada para soportar la carga máxima anotada. El exceder estos límites puede causar inestabilidad, colapsarse y/o causar serias lesiones.

ADVERTENCIA: Riesgo de lesiones a las personas - no coloque un televisor sobre muebles. Este mueble no está aprobado para su uso con un televisor.

Página 29

Registre su producto para recibir lo siguiente:

- * Detalles de nuevas tendencias - Vistazo a lo nuevo
- * Encuestas - alec su voz entre su comunidad
- * Códigos de ofertas y descuentos exclusivos
- * Fácil y rápido servicio de partes de remplace

Para registrar su producto, visite ameriwoodhome.com

Clasificación de 5 estrellas

Visite el sitio web de su tienda local, califique su comprado y denos sus comentarios!

Nos gustaría enviar un gran "Agradecimiento" a todos nuestros clientes por tomarse el tiempo de ensamblar este producto de Ameriwood Home, y por darnos sus valiosos comentarios.

Gracias

Couverture Avant

CE LIVRET D'INSTRUCTION CONTIENT DES INFORMATIONS **IMPORTANTES** SUR LA SÉCURITÉ. VEUILLEZ LIRE ET GARDER POUR UNE RÉFÉRENCE FUTURE

Ne retournez pas ce produit! Contactez notre équipe de service à la clientèle amicale d'abord pour obtenir de l'aide.

Appelez-nous: 1-800-489-3351 (sans frais) du Lundi au Vendredi de 9h à 17h Heure Centrale

Visitez: www.ameriwoodhome.com

ATTENTION

Le meuble peut basculer et causer des blessures graves ou la mort.

Ancrer le meuble à une planche murale dans le mur (si indiqué).

Ne laissez pas les enfants grimper sur le meuble.

Placez les articles lourds sur les étagères ou dans les tiroirs inférieurs.

Astuces Utiles (page 2)

-Ouvrez votre article dans la zone que vous prévoyez de le garder pour moins de levage lourd

-Identifier, trier et compter les pièces avant d'essayer d'assembler

-Les goujons de compression sont taraudés avec un Marteau

-Les glissières sont marquées d'un R (droit) et d'un L (gauche) pour un bon placement

-Assurez-vous toujours de faire face la pointe situé sur le haut de la Serrure de Came vers le bord extérieur

-Utiliser tous les clous fournis pour le panneau arrière et les répartir également

-Le panneau arrière doit être utilisé pour vous assurer que votre appareil est robuste

-N'utilisez pas de produits chimiques agressifs ou de nettoyeurs abrasifs sur cet appareil

-Ne jamais pousser, tirer, ou faire glisser votre meuble

Avant de Commencer (page 3)

-Lisez attentivement chaque étape et suivez le bon ordre

-Séparez et comptez toutes vos pièces et matériaux

-Donnez-vous suffisamment de place pour l'assemblage

-Avoir les outils suivants: tournevis à tête plate, #2 tournevis Phillips, et Marteau

-Attention: Si vous utilisez une perceuse électrique ou un tournevis électrique pour visser, veillez à ralentir et arrêter lorsque la vis est bien serrée. Le non-respect de cette consigne peut endommager la vis.

Système de Fixation de Came (page 3)

Ce Système de Fixation de Came sera utilisé tout au long de l'assemblage

Page 11

Côté gauche Côté droit

Page 13

Ne serrez pas complètement la vis.

Page 15

IMPORTANT! LE PANNEAU ARRIÈRE EST UNE PARTIE STRUCTURELLE DE CETTE UNITÉ ET DOIT ÊTRE INSTALLÉ CORRECTEMENT.

Retournez soigneusement l'unité sur sa face avant comme indiqué.

Fixez le panneau arrière comme indiqué en le clouant directement dans les bords bruts.

Assurez-vous que l'unité est bien carrée.

Les distances d'un coin à l'autre du meuble doivent être égales, comme indiqué.

Assurez-vous que notre unité est bien carrée.

Les distances d'un coin à l'autre du meuble doivent être égales, comme indiqué.

Alignez le bord inférieur du panneau arrière avec le bord inférieur du bas (E).

Page 16

Ne confondez pas les vis n° 7 et n° 9/10. La vis n° 7 a une tête et un corps plus grands.

Page 17

Pour la maçonnerie, le béton ou d'autres matériaux muraux :

Consultez votre quincaillerie locale pour obtenir des ancrages appropriés afin de fixer solidement le support de sécurité.

IMPORTANT : CETTE UNITÉ DOIT ÊTRE FIXÉE AU MUR POUR ÉVITER TOUT BASCULEMENT. SUIVEZ CES INSTRUCTIONS POUR INSTALLER LE SUPPORT DE SÉCURITÉ ANTI-BASCULEMENT FOURNI AVEC CE PRODUIT.

AVERTISSEMENT

Le basculement d'un meuble peut entraîner des blessures graves ou mortelles par écrasement.

Pour éviter le basculement :

- * Installer le dispositif de retenue anti-basculement fourni
- * Placez les articles les plus lourds dans les tiroirs les plus bas
- * Ne posez pas de téléviseurs ou d'autres objets lourds sur le dessus de ce produit, sauf s'ils ont été spécifiquement conçus à cet effet
- * Ne laissez jamais les enfants grimper ou s'accrocher aux tiroirs, aux portes ou aux étagères
- * N'ouvrez jamais plus d'un tiroir à la fois

L'utilisation de dispositifs de retenue en cas de basculement ne peut que réduire le risque de basculement, mais pas l'éliminer complètement

Page 17

OPTION 1 : Fixation dans un montant de mur (méthode privilégiée)

À l'aide d'un détecteur de montants, localisez un montant dans le mur. Placez votre unité contre le mur, avec le support de sécurité aligné à cet endroit. Pour faciliter l'insertion de la vis, vous pouvez percer un trou pilote de 3 mm (1/8") de diamètre à travers le support de sécurité dans le montant. Enfoncez la vis à travers le support de sécurité dans le montant du mur. Serrez la vis qui n'a pas été entièrement serrée à l'étape 5.

OPTION 2 : Fixation dans les cloisons sèches

Placez votre unité contre un mur, à l'endroit souhaité, et marquez le mur à travers le support de sécurité, puis mettez votre unité de côté. Percez un trou de 5 mm de diamètre (3/16") dans le panneau mural. Tapez sur l'ancrage mural dans le trou jusqu'à ce qu'il soit affleurant. Mettez votre unité en place et fixez le support mural à l'ancrage mural à l'aide de la vis. Serrez la vis qui n'a pas été entièrement serrée à l'étape 5.

Page 26

Remarque : les trous des supports de tiroir sont fendus. Les façades des tiroirs peuvent être ajustées en desserrant les vis, en effectuant les ajustements nécessaires puis en resserrant les vis.

Page 27

Réglage de la porte

Pour régler la hauteur verticale :

Desserrez les vis « A » sur les deux charnières. Celles-ci se trouvent généralement dans des trous oblongs, ce qui vous permet de les régler de quelques millimètres vers le haut ou vers le bas. Puis, resserrez-les.

Pour régler la profondeur :

Desserrez la vis « B » et réglez la porte.

Pour ajuster latéralement :

Desserrez la vis « C » sur les DEUX charnières et serrez « B » pour déplacer la porte vers l'extérieur. Desserrez la vis « B » et serrez la vis « C » pour déplacer la porte vers l'intérieur.

Page 28

CHARGES MAXIMALES

Ce meuble a été conçu pour supporter les charges maximales indiquées. En excédant ces limites de charge, le meuble pourrait devenir instable, s'effondrer, et/ou causer des blessures graves.

AVERTISSEMENT : Risque de blessure corporelle - ne pas placer une télévision sur ce meuble. Ce meuble n'est pas approuvé pour une utilisation avec une télévision.

Page 29

Enregistrez votre produit pour recevoir les éléments suivantes:

- * Détails sur les nouvelles tendances - un aperçu sur les nouveautés
- * Sondages - avoir une voix au sein de notre communauté
- * Offres exclusives et codes promo
- * Service de pièces de rechange rapide et facile

Pour enregistrer votre produit, visitez ameriwoodhome.com

5 Étoiles

Visitez le site Web de votre détaillant local, évaluez votre produit acheté et laissez-nous quelques commentaires !

Nous tenons à offrir un grand "Merci" à tous nos clients pour avoir pris le temps d'assembler ce produit "Ameriwood Home", et de nous donner vos commentaires précieux.

Merci